

# Hard as Rocks



ELDORADO



STONE

®



## CONSTRUCTION GUIDE

ELDORADO STONE™ VENEER AND HARD AS ROCKS APPLICATION SYSTEM

VERSION 1.3 July 2024

FOR YOUR LOCAL LICENSED APPLICATOR AND HARD AS ROCKS DISTRIBUTOR PLEASE PHONE

**0800 353 672**

## **PRODUCT DESCRIPTION**

*Eldorado Stone™ veneer and Hard as Rocks Application System* is a simulated stone veneer cladding system designed to imitate the look of natural stone. The materials used in the manufacture of Eldorado Stone™ veneer are lightweight aggregates, Portland cement and iron oxide pigments that are cast to mimic different styles of stone. The weight of the cladding system in total does not exceed 80kg/m<sup>2</sup>.

Hard as Rocks New Zealand's installation procedure of this stone veneer cladding is generally over conventional timber framing with studs at not more than 400 mm centres, a nominal 20mm drained and ventilated cavity and a fibre-cement backing sheet sealed with a proprietary moisture resistant coating. Proprietary stainless steel ties are used as a mechanical fixing between the timber framing and the mortar/stone veneer. This cast stone veneer and its New Zealand installation system can be used on domestic and light commercial buildings where domestic construction techniques are used as well as solid construction buildings as detailed below.

## **SCOPE OF USE**

No substitutions are permitted for Eldorado Stone Veneer & Hard as Rocks Application System.

The Eldorado Stone™ veneer and Hard as Rocks Application System has been appraised as an external wall cladding system for buildings within the following scope:

- the scope limitations of NZBC Acceptable Solution E2/AS1, Paragraph 1.1; and,
- constructed with timber framing complying with the NZBC; and,
- with a risk score of 0-20, calculated in accordance with NZBC Acceptable Solution E2/AS1, Table 2; and,
- situated in NZS 3604 Wind Zones up to, and including, Extra High.

The Eldorado Stone™ veneer and Hard as Rocks Application System must only be installed on vertical surfaces (except for sills which must have a minimum 10° slope and be waterproofed in accordance with the Technical Literature)

## **RESPONSIBILITIES**

- a. **Hard as Rocks** is responsible for the quality of Eldorado Stone™ veneer and its installation system.
- b. Quality of installation on site is the responsibility of **Hard as Rocks** licensed applicators.
- c. **Building designers** are responsible for all components of the building and substrate design, to comply with NZBC, and for the incorporation of the *Hard as Rocks Application System* into their design in accordance with the instructions of Hard as Rocks technical literature.
- d. **Builders** are responsible for the supply and installation of the fibre cement board with Hard as Rocks Tags, all relevant watertight flashings behind all fibre cement board sheet joints, sealant over the top of the sheet joints and sealing around joinery and all workmanship and installation of the substrate to meet Hard as Rocks Technical Literature and the NZBC.
- e. **Installation of the stone veneer** and the stone veneer accessories supplied by Hard as Rocks and **approved installers** must be carried out only by Hard as Rocks licensed applicators.
- f. **Building owners** are responsible for the maintenance of *Eldorado Stone™ veneer and Hard as Rocks Application System* in accordance with the instructions of Hard as Rocks literature.

### **• BUILDERS**

- *Weathertightness and flashings are the sole responsibility of the builder and Hard as Rocks Ltd accepts no liability for incorrect or inadequate installation.*



## **SUBSTRATES**

### **Concrete Masonry/Brickwork or Concrete Panels**

Eldorado Stone™ veneer can be direct fixed to many masonry surfaces. Each application should consider many aspects including weather tightness (where applicable), footing loading (particularly over brick applications where brick tie loadings need to also be factored and calculated) and returns into window and door rebates. The BRANZ appraised *Eldorado Stone™ veneer and Hard as Rocks Application System* does not cover these applications so it is up to designers and engineers to incorporate the system to meet the NZ building code.

In general applications, the surface must be totally free of oil, grease, paint, curing compounds, sealers, mould release agents, dust or other loose contaminating materials. If any of these materials are present the surface must be cleaned back to the original surface by sandblasting, water blasting, acid etching or wire brushing.

Prior to stone application the surface must be waterproofed using an approved water proofing slurry which is brushed or rolled on to a depth of not more than 2mm.

### **FIBRE CEMENT BOARD**

The most common and cost-effective form of application is over an approved fibre cement board substrate. We use and recommend BGC Stonesheet 9mm sheets.

Installation of the fibre cement board and relevant flashings is the responsibility of the builder and must be carried out in accordance with the manufacturer's technical instructions to ensure compliance with the requirements set out in E2 *External Moisture* of the New Zealand Building Code.

All flashings must be installed in accordance with building code requirements. To maintain the weather-resistance of the exterior wall on which the stone products are installed, rigid, corrosion-resistant flashings and a means of drainage shall be installed at all penetrations and terminations of the stone cladding. Flashing type and locations shall be in accordance with the requirements of the applicable code.

The cavity vent strip must be in accordance with NZBC Acceptable Solution E2/AS1, Paragraph 9.1.8.3. The vent strip must be manufactured from PVC, aluminium or stainless steel, and be punched with 3 - 5 mm holes or slots which provide a minimum ventilation opening area of 1000 mm<sup>2</sup> per lineal meter of wall. The selected cavity vent strip must be installed with the bottom of the vent strip flush with the underside of the cavity battens. Note: A minimum 15 mm drip edge to the bottom of the fibre cement sheet must be maintained at all times.

Minimum 45 mm wide x 18 mm thick H3.1 treated timber cavity battens, or proprietary cavity battens covered by a valid BRANZ Appraisal must be installed over the building underlay to the studs at maximum 400 mm centres. The battens must be fixed in place with 30 x 2.5 mm hot-dipped galvanised flat head nails at maximum 800 mm centres.

9mm thick fibre cement sheets complying with AS/NZS 2908 Part 2 may be installed vertically or horizontally. All vertical sheet edges must be supported and fixed through the cavity battens to the wall framing. At the base of the wall, the sheets must hang 50 mm below the supporting framing.

### **Where to purchase BGC Fibre cement Board**

	<b>Placemakers</b>		<b>Bunnings</b>		<b>Carters</b>
	<b>Code</b>	<b>SKU #</b>	<b>Code</b>	<b>SKU #</b>	<b>Product Code</b>
9mm Stonesheet	DSS93012	3100355	DSS93012	163631	
Joint tape	780	3100356	780	163637	
Edge sealer	846	3100351	846	163644	

## INSTALLATION OF FIBRE CEMENT BOARD

### Diagram: *Batten and Fibre Cement board set-out*



### BUILDERS

- All exterior applications are to be installed over a 20mm drained cavity system
- Use 90 degree moulded flashings for all internal and external corners (PVC, galvanised or Stainless steel as required)
- Use Flat back flashings behind all fibre cement sheet joints (horizontal and vertical)
- Back flashings are to be installed over the top of the cavity batten and behind the fibre cement board
- Use suitably shaped back flashings to all junctions with other claddings
- Cavity vent strip to be used at bottom of battens
- Builder to install BRANZ appraised MS Silicon to all window jambs and sills.
- Builder to install MS Silicon or 65mm wide flashing tape to all fibre cement board sheet joints, corners and cladding junctions

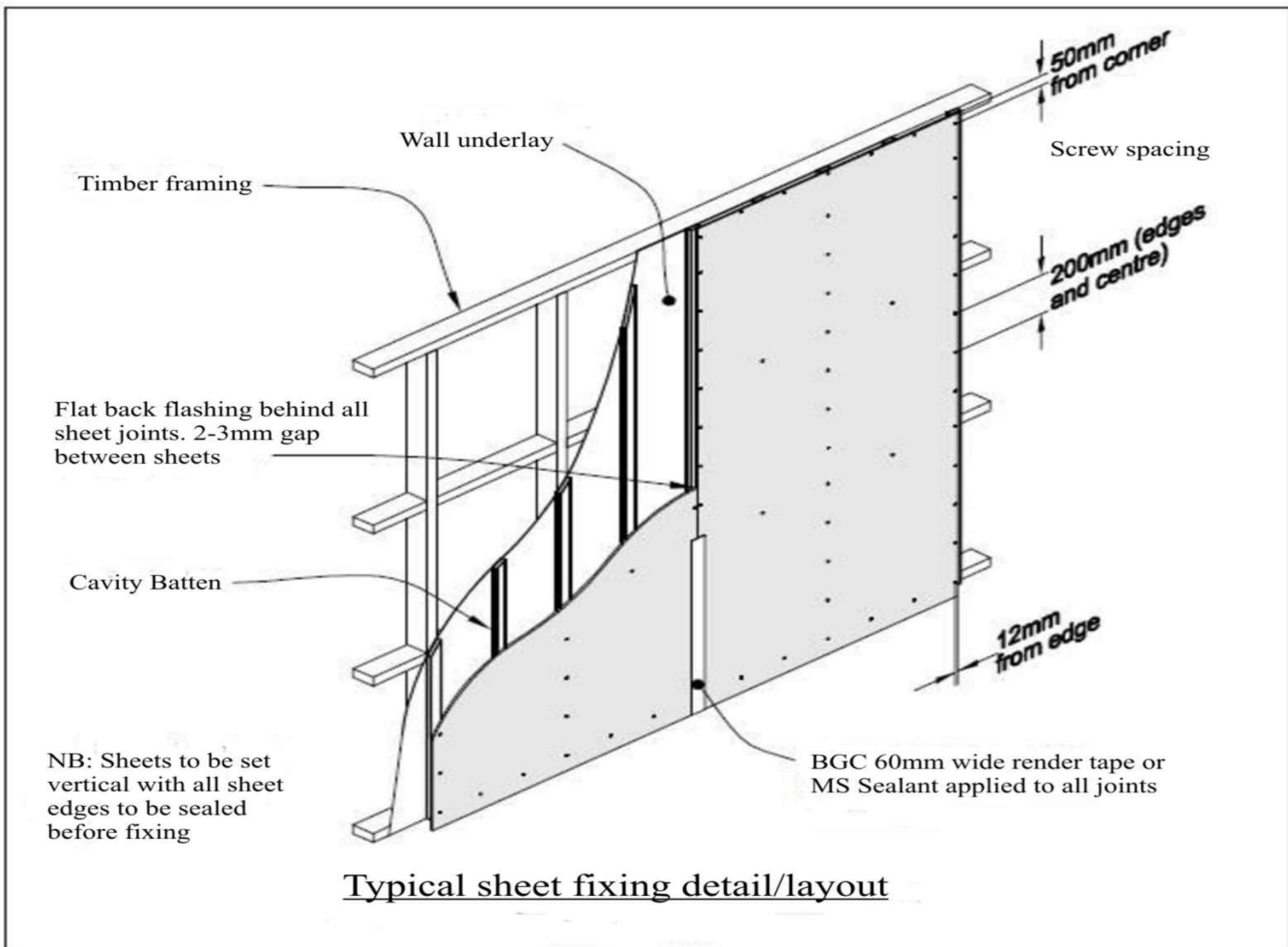

## **HARD AS ROCKS SCREW & TAG FIXING**

All exterior fibre cement board fixing must use 10g x 65mm Stainless Steel Screws with either M6x18mm x1.6mm Stainless steel Washers or 60mm Stainless Steel Hard as Rocks Tags where applicable.

Interior work can be fixed with the same 65mm screws and washers @ 200mm centres or min 50mm galvanised flat head clouts @ 150mm centres

Fixing requirements table	Up to 3m High Vertical spacings	Above 3m High Vertical spacings
Wind zones Low, medium and High and Earthquake Zone 1 and 2 Use 9mm BGC Stone sheet	Max. 200mm Tags & Washers to alternate	Max. 200mm Tags only
Wind zones Very high, and Earthquake zones 3 and 4 9mm BGC Stone sheet	Max. 200mm Tags only	Max. 150mm Tags only

*Note: For standard application, the maximum vertical fixing spacing is 200mm. The maximum horizontal fixing spacing to studs is 400mm*

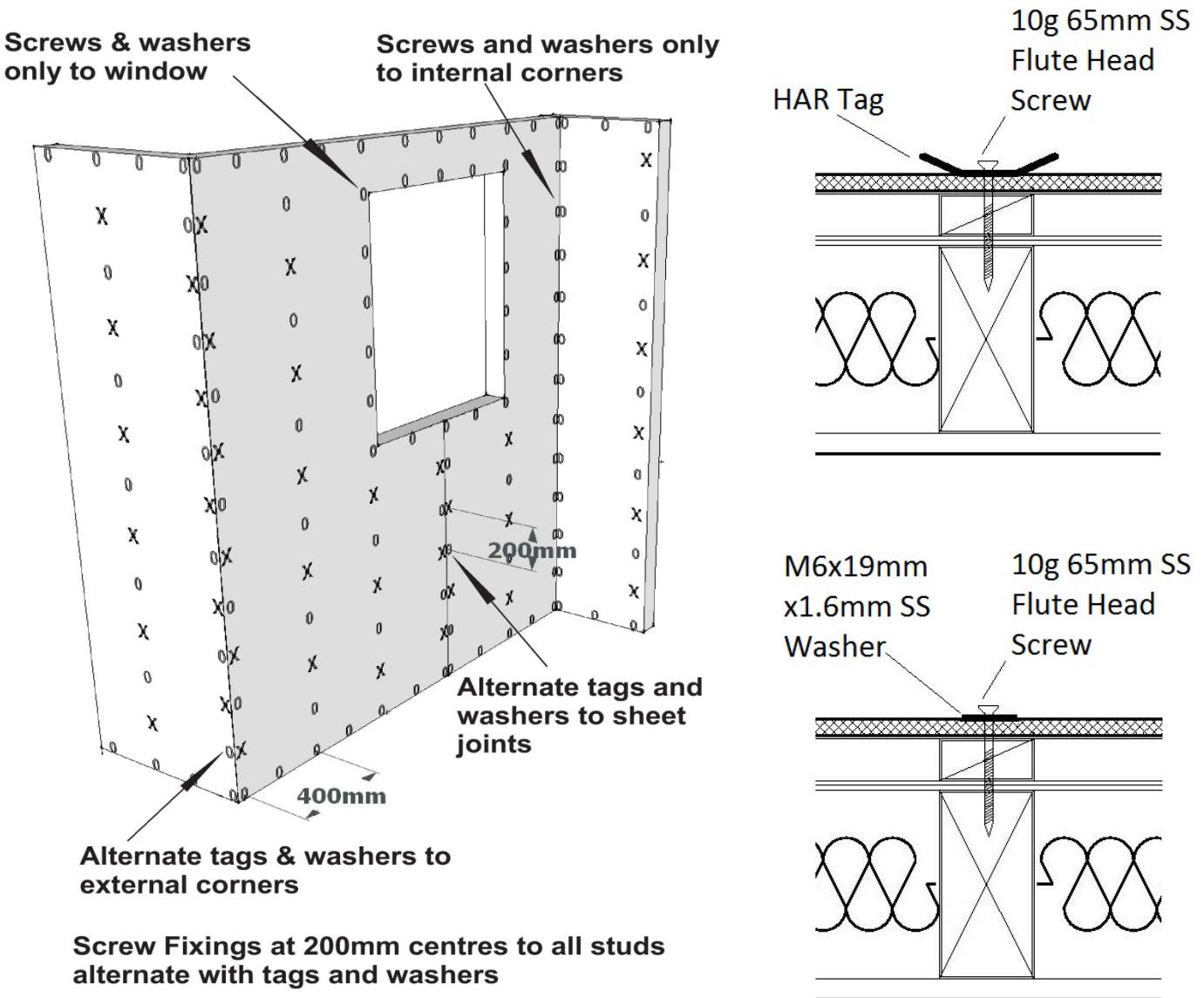

**Diagram:** Alternating positions of screws and washers with Hard as Rocks Tags both fixed using 10g x 65mm Stainless steel screws

## FIBRE CEMENT BOARD JOINTS – Corners

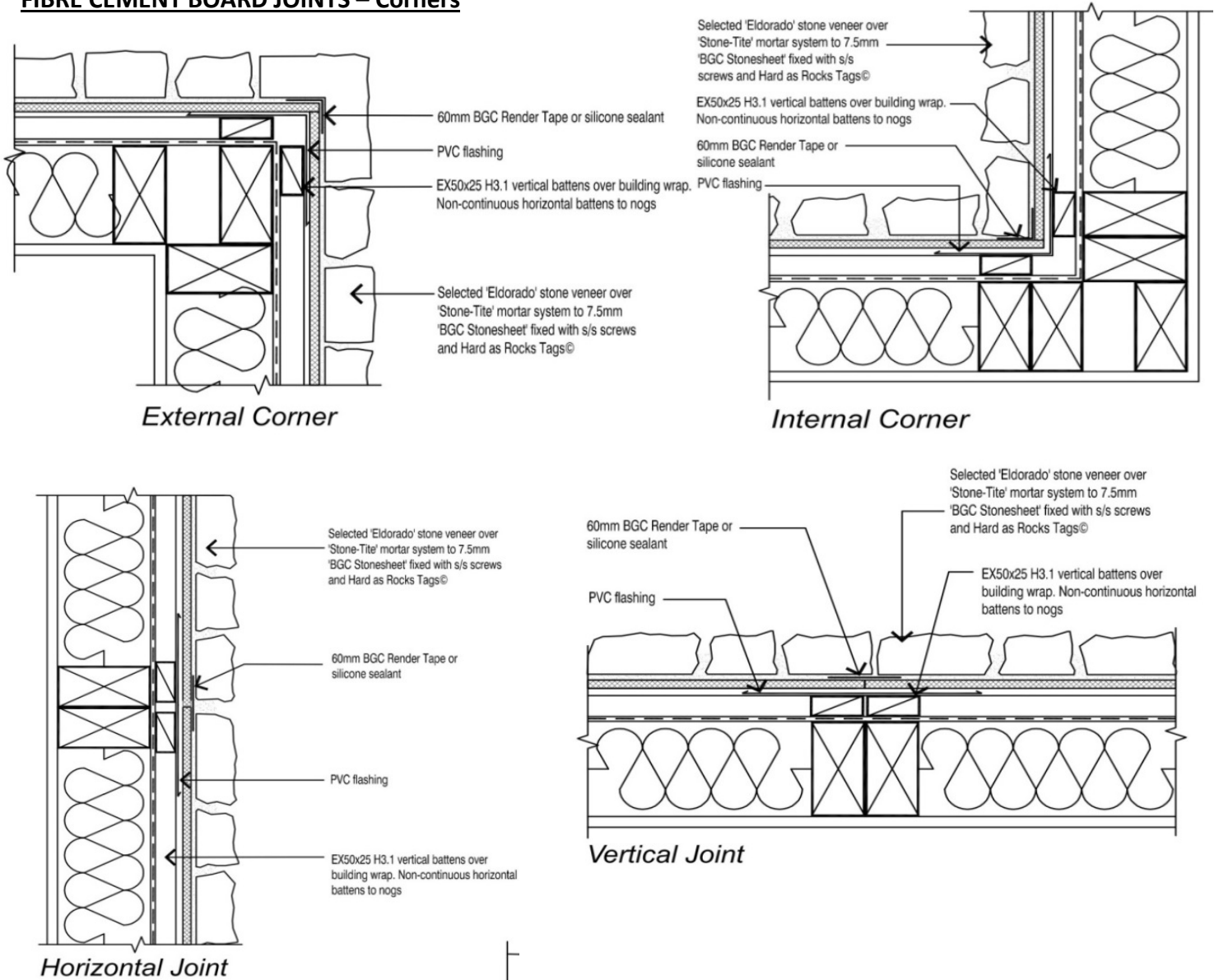

### BUILDERS

- All corners to have a 90 degree flashing behind the fibre cement board and over the cavity batten.
- All corners to have 60mm flashing tape or MS Silicone sealant applied to sheet joint.
- All vertical and horizontal sheet joints to have flat back flashing and 60mm flashing tape or MS silicone sealant to exterior sheet joint.
- Control joints to be fixed over double stud and double cavity batten.
- Builders are to make sure substrate has no gaps and is watertight with flashings and sealant



### Vertical and Horizontal Control Joints

Vertical control joints to be formed at maximum 5.4m centres, aligned with any control joint in the structural framing, or where the Eldorado Stone Veneer System abuts to different cladding types. Confirm the location of all control joints prior to installation. Horizontal control joints to be formed on cavity batten framing at maximum 5.4m or at inter-storey floor levels in accordance with Hard as Stone requirements and as shown on plans.

## New Zealand Building Code Compliance (NZBC)

BGC fibre cement sheets must be used, installed and maintained in accordance with this Technical Literature to meet the following provisions of the New Zealand Building Code (NZBC).

### Clause B1 Structure

BGC fibre cement sheets will meet performance B1.3.1, B1.3.2 and B1.3.4. Relevant information on the physical conditions pertaining to B1.3.3 is included in this literature.

### Bracing

BGC fibre cement sheets can be used to provide racking resistance to timber framed walls against wind and earthquake loads in accordance with NZBC, when applied directly to studs. Cavity battens and an additional fibre cement outer cladding is required.

### Clause B2 Durability

When used as an external substrate for an applied coating system BGC fibre cement will meet the following provisions of the NZBC.

- B2.3.1(a) - 50 years for structural (bracing) applications. Stainless steel fixings must be used for all bracing sheets.
- B2.3.2(b) - 15 years for general applications. Stainless steel fixings must be used in corrosive conditions such as geothermal hot spots or coastal zones (within 500m of the sea).

Coating systems, seals and flashings must be maintained to ensure moisture does not penetrate the cladding system and sheets and that fixings remain dry at all times.

The homeowner should follow the BRANZ Homeowner's Manual to maintain their dwelling. this manual provides a recommended maintenance check list.

BGC fibre cement is expected to have the service life of at least 50 years.

### Clause E2 External Moisture

BGC fibre cement when used in conjunction with an external applied finishing system (jointing and coating) that meets NZBC B2, E2 and F2, will meet performance E2.3.2.

Head flashings and sill trays must be used at all joinery penetrations, and jambs must be sealed as per the relevant instructions in Acceptable Solution E2/AS1 third edition.

### Clause F2 Hazardous Building Materials

BGC fibre cement is not considered a health hazard to people and therefore meet the performance F2.3.1.

### Sheet Cutting and Preparation

BGC fibre cement sheets may be cut to size on site. If using power tools for cutting, drilling or sanding they must be fitted with appropriate dust collection devices or alternatively an approved (P1 or P2) dust mask shall be worn.

It is recommended that work always be carried out in a well-ventilated location. If a cut edge is to be flush-joined it must be prepared with a recessed edge.

### Cutting

The most suitable cutting methods are:

#### ■ Score and snap

Using a straight edge, score the sheet face 4 or 5 times with a tungsten tipped

'score and snap' knife. While supporting the scored edge with the straight edge snap the sheet upward for a clean break.

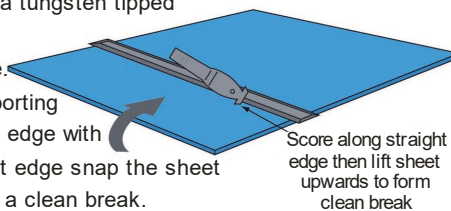

#### ■ Hand Guillotine

A fibre cement hand guillotine produces clean straight edges and is ideal for cutting BGC fibre cement sheets.

Make the guillotining cut on the off-cut side of the line to allow for the blade thickness.

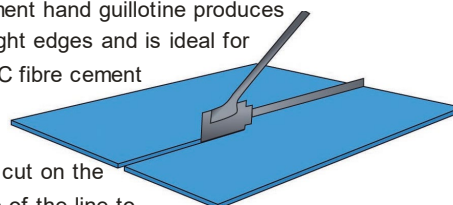

#### ■ Notching

Notches can be made by cutting two sides of the notch with a hand saw or guillotine. Score along the third side with a 'score and snap' knife, then snap upwards while supporting the scored edge to remove the notch.

## ■ Hand Sawing

Hand sawing is suitable for general cutting operations, small cuts, notches and small penetrations.

For accuracy and neatness, mark out the cut lines on the face side of the sheet prior to sawing.



When sawing, the back of the sheet should be

supported close to the cut. A fine toothed saw can be used. A quick jabbing action gives best results.

## Holes and Penetrations

### ■ Drilling

BGC fibre cement sheets can be drilled using normal high-speed drill bits, do not use the drill's hammer function.

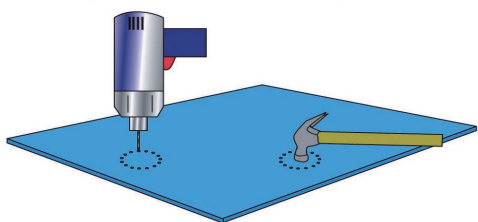

Small rectangular or circular penetrations can be made by drilling a series of small holes around the perimeter of

the cut out, then tapping out the waste piece from the sheet face. Tap carefully with a hammer while supporting the underside of the opening to avoid damage. Clean up any rough edges with a rasp if necessary.

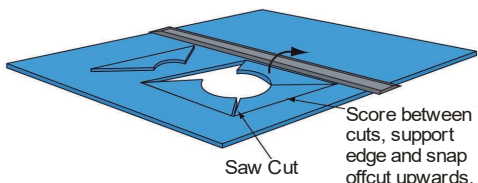

Large rectangular openings such as for air conditioners, are formed by deeply scoring

the perimeter of the opening with a 'score and snap' knife. Next form a hole in the centre of the opening (see method above) then saw cut from the hole to the corners of the opening.

Finally snap out the four triangular segments to form the opening. Clean rough edges with a rasp if necessary.

## Fixing Instructions

BGC fibre cement sheets must be dry before fixing to the framing structure. Sheet edges must be joined over a stud or continuous line of noggings. Sheet cuts, which are to be flush jointed, must be recessed on site. The Hitachi 'Easy Bevel' (Model EBCOMBO) is specifically designed for this purpose.

## Framing

- Framing must be constructed to comply with the New Zealand Building Code (NZBC). Compliance with the NZBC can be met by timber framing designed and constructed in accordance with NZS 3604 for non-specific design, or in accordance with NZS 3603 and NZS 4203/4251 for specific design.
- The framing must be set to a true plane to ensure a straight finish to the wall.
- The moisture content of timber framing must be less than 16% when the cladding sheets are fixed. If sheets are fixed to 'wet' framing problems may occur at a later date due to excessive timber shrinkage. It is strongly recommended that kiln dried framing is used.
- Timber framing, for sheet joints, must have a minimum face width of 45 mm (nominal 50 mm).
- Intermediate studs with a minimum face width of 35 mm (nominal 40 mm) may be used.
- Studs must be spaced at maximum 400 mm centres. Noggings need to align with sheet joints when used for horizontal fixing. BGC fibre cement sheets must not be joined off the framing.

## Impact Resistance

BGC Fibre Cement has good resistance to hard and soft body impacts likely to occur in residential and light commercial use. When used in commercial or industrial situations, or other high impact situations, the designer should consider protection measures such as the installation of barriers or bollards to vulnerable areas.

## Wind Face Loads

BGC Fibre Cement sheets may be used in all Building Wind Zones of NZS 3604, including Very High.





## PILLARS

- The optimum framing size for stone pillars is 400mm square. This is the timber framing and fibre cement board. As most stone profiles are individual pieces this does not have to be exact (except Stacked stone profile) however making the pillar wider may increase the cost as most quoting/costings are based on 400x400 unless otherwise stated.
- Remember that the stone will add approximately 100mm to the finished size (50mm thick)
- **When framing a pillar for our Stacked Stone profile please frame the pillar to 300mm square exact or 400mm square exact including fibre cement board. This gives the best visual finish and is economical price wise.**
- Always use H3.2 timber for all pillar framing. Framing structure is to be rigid and strong as any movement in structure may cause cracking to corners. There is no warranty for cracked corners as a result of substrate movement.
- Use building wrap or builder's paper behind the fibre cement board.
- All corners must be back flashed and have either 60mm flashing tape or MS silicone sealant applied to exterior sheet joint
- 50mm flat head galvanised clouts at 150mm centres can be used on pillars where the fibre cement board is direct fixed to framing. Hard as Rocks 65mm SS screws and washers must be used where a 20mm cavity batten has been specified.

### Half high pillars with central post with cap framed at 300x300mm

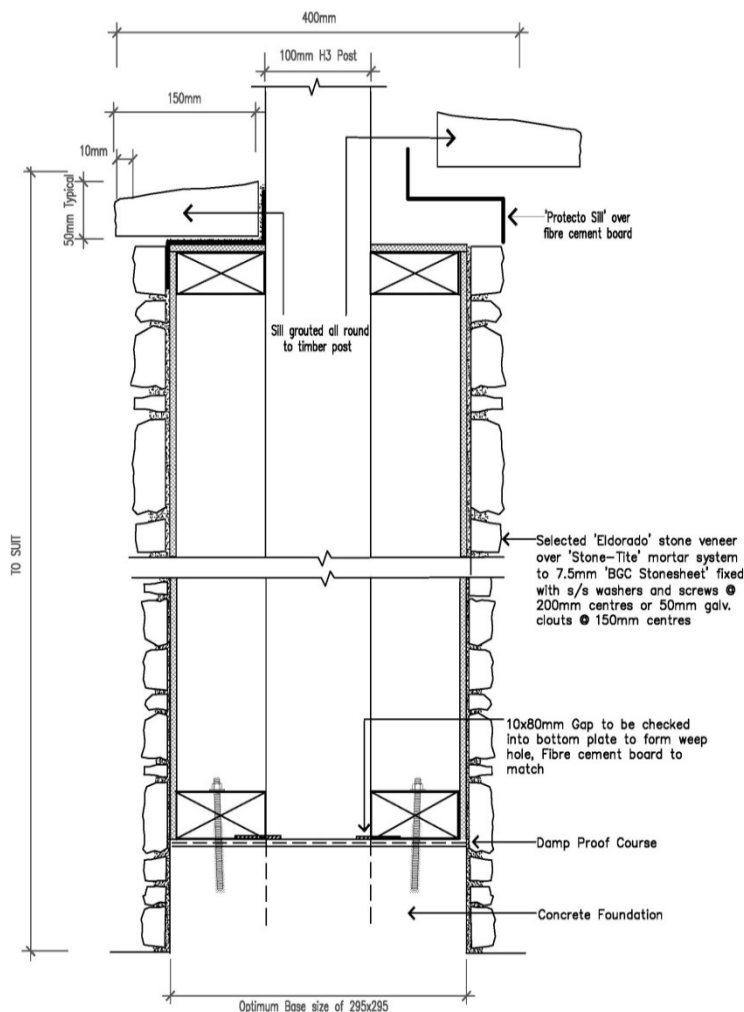

### Full height pillars under a flat or raking soffit (note flashing to raked soffit)

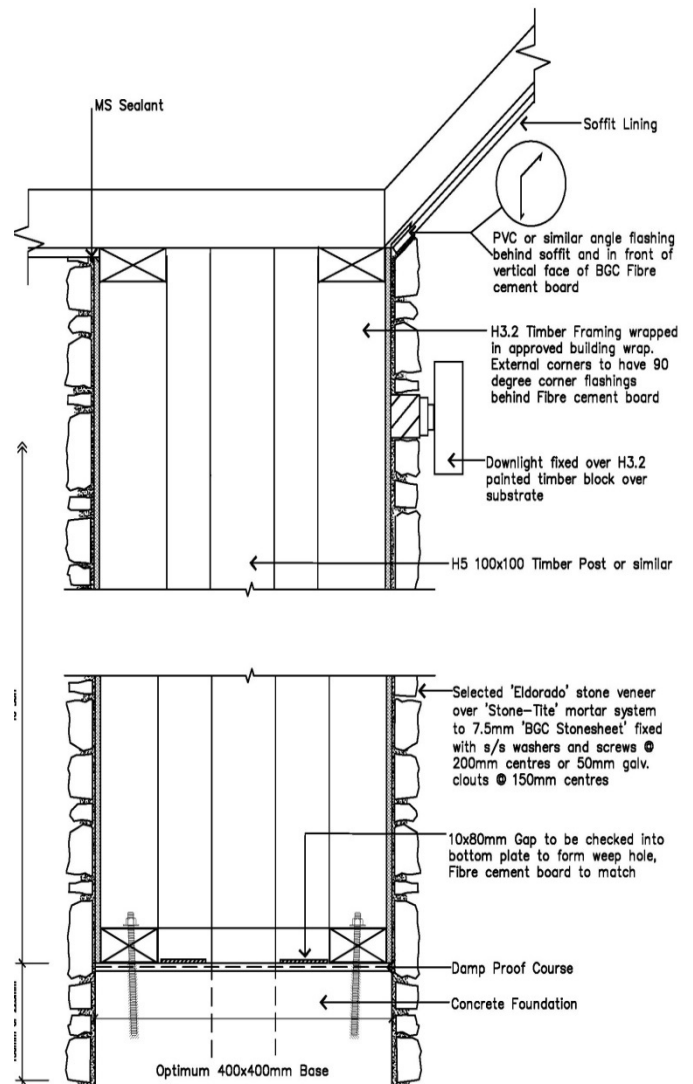

## Internal stonework to fireplaces and feature walls

When installing stone to an interior feature wall or fireplace you have a couple of options to consider depending on the space you have available and the look you are wanting to achieve. If you are restricted by space or other complications and just want a flat feature say behind a fireplace you can direct fix the fibre cement board to the wall or over the gib. This is an economical option as it saves on the cost of corner stones however consideration should be given to hiding the edge of the fibre cement board and stone by using a number of trim options including timber facing or scribe, or a tile trim or similar.

**Diagram:** *Substrate direct-fixed*

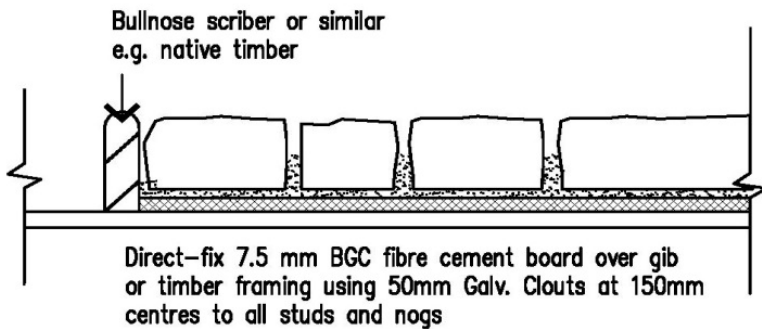

The second option is to pack out the area off the wall using 45mm thick timber framing and install the fibre cement board over the top. When the stone is applied your installer will add a corner stone up each side which will make the whole wall look like it is approx. 100mm thick giving a sense of depth and dimension.

**Diagram:** *Substrate packed off the wall for a sense of depth*

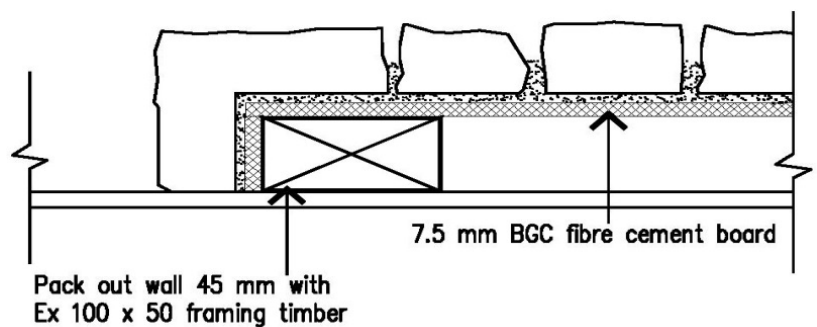



## FIREPLACES AND FEATURE WALLS

- 50mm flat head galvanised clouts at 150mm centres can be used on interior applications where the fibre cement board is direct fixed to framing.
- For inbuilt fires, the fire box should be flush mounted to the fibre cement board with the fire fascia or surround pushed back against the fibre cement board as if it were a window. Your installer will lay the stone up to the edge of the fascia.
- If the fire surround or fascia is designed to be removed for servicing, thought should be given as to how to lay the stone to accommodate this. Some fires require a gap needing to be left immediately above the fascia in order to lift the fascia up and then off. You can disguise this gap with a negative detail or suitable flashing.
- If you are mounting a TV bracket remember to install extra timber nogs or blocks into the framing to accommodate the bracket before you install the fibre cement board.
- Remember that the stone is approximately 50mm thick so if you are returning corners into a TV recess make allowances for the thickness of the stone for sizing.

Shelving units and 'Display' box installations



Picture framed TV Recess

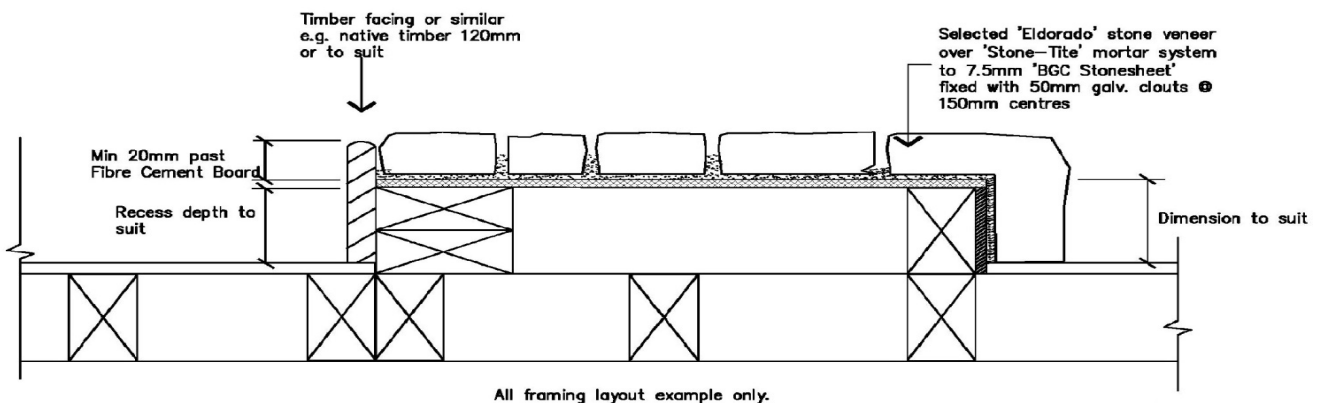
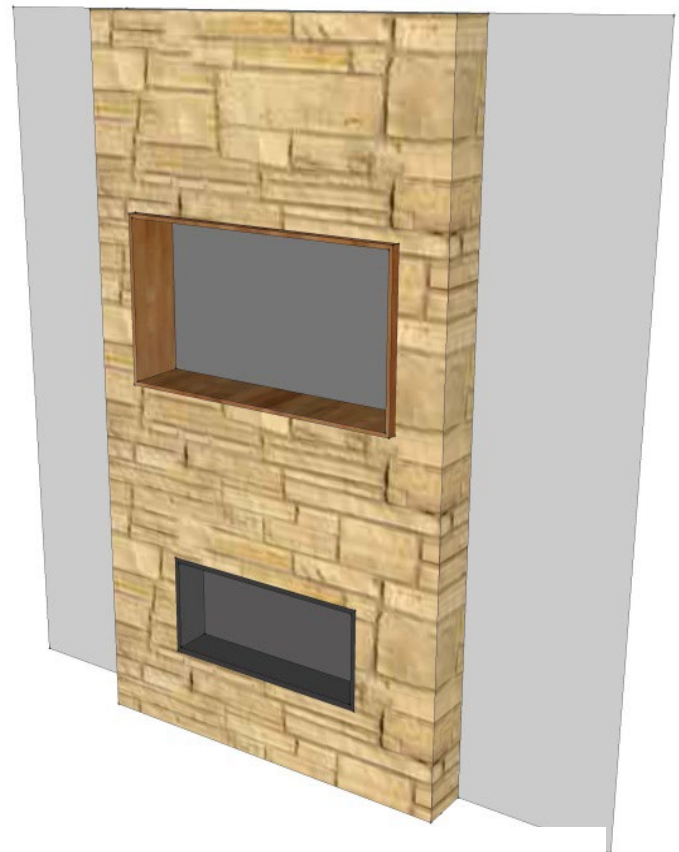

## (1a) Standard Slab Edge

Selected 'Eldorado' stone veneer over 'Stone-Tite' mortar system to 7.5mm 'BGC Stonesheet' fixed with s/s screws and Hard as Rocks Tags©

EX50x25 H3.1 vertical battens over building wrap. Non-continuous horizontal battens to noggs

Stone to overhang substrate by 20mm

Proprietary punched cavity closer

50mm  
225 to FGL  
150 to paving

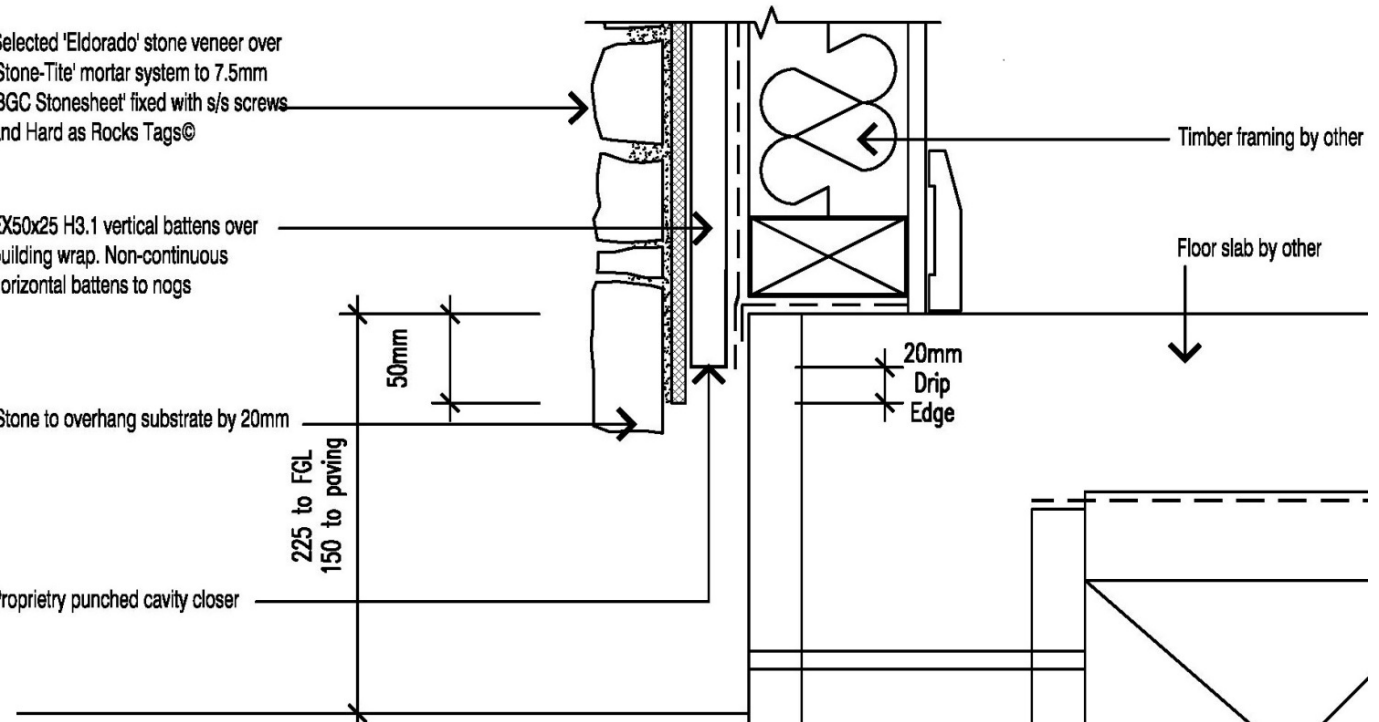

## (1b) Rebated Slab Edge

Selected 'Eldorado' stone veneer over 'Stone-Tite' mortar system to 7.5mm 'BGC Stonesheet' fixed with s/s screws and Hard as Rocks Tags©

EX50x25 H3.1 vertical battens over building wrap. Non-continuous horizontal battens to noggs

10x100mm wide horizontal weephole at base of rebate - approx. 600c/c

Rebate for batten and backing sheet

100  
19 gap  
20 gap  
27  
225 to FGL  
150 to paving

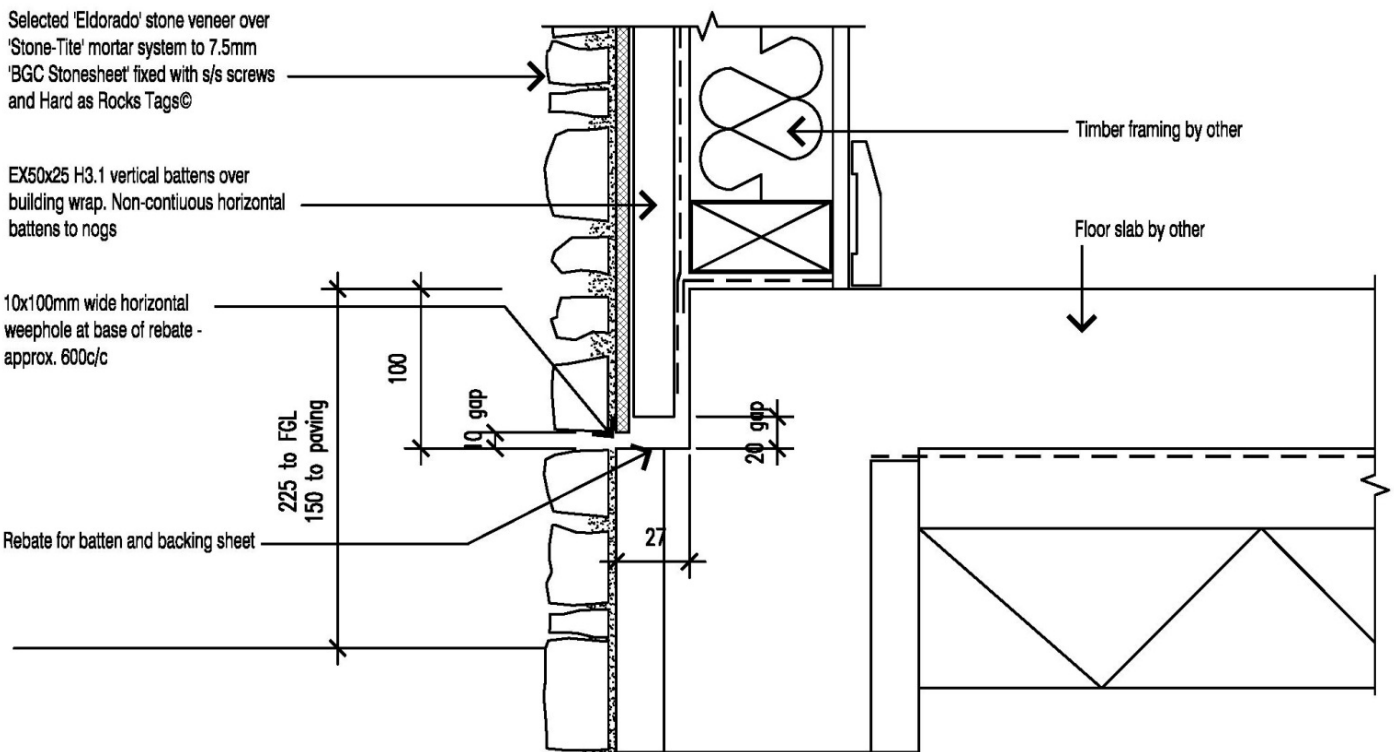

### HARD AS ROCKS SUGGESTED DETAILS ONLY – DETAILS TO BE APPROVED BY LOCAL AUTHORITY & COMPLY WITH NZBC

**Builders** are responsible for the supply and installation of the fibre cement board with Hard as Rocks Tags, all relevant watertight flashings behind all fibre cement board sheet joints, sealant over the top of the sheet joints and sealing around joinery and all workmanship and installation of the substrate to meet Hard as Rocks Technical Literature and NZBC.

### (1g) Soffit Detail

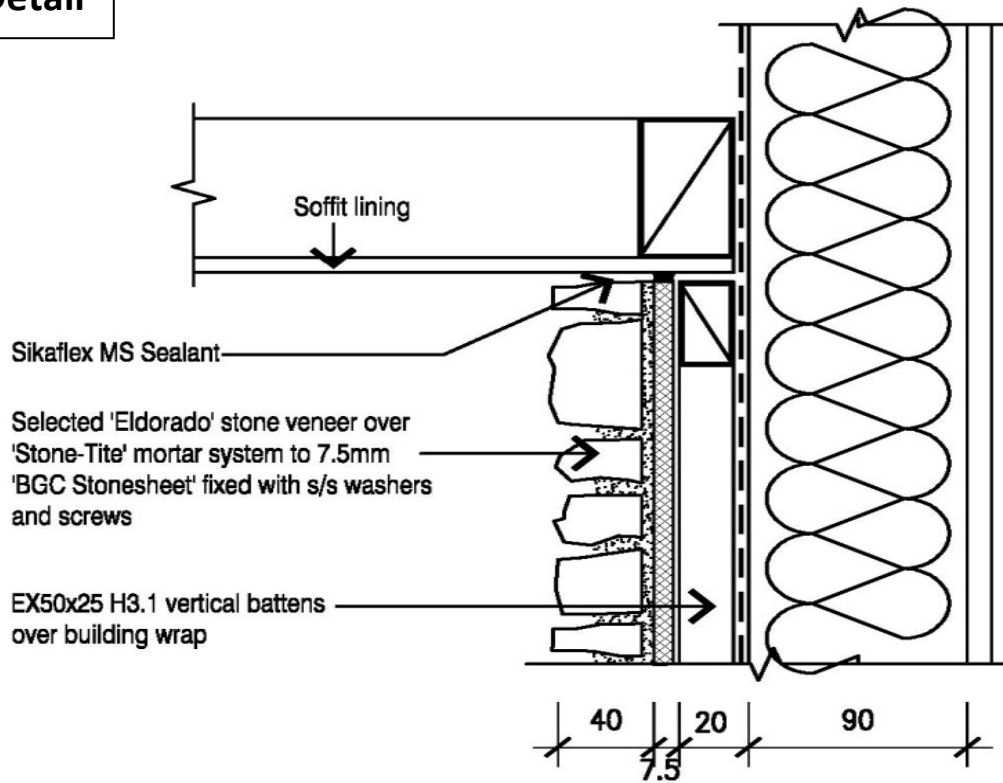

### (1j) Garage Jamb Detail

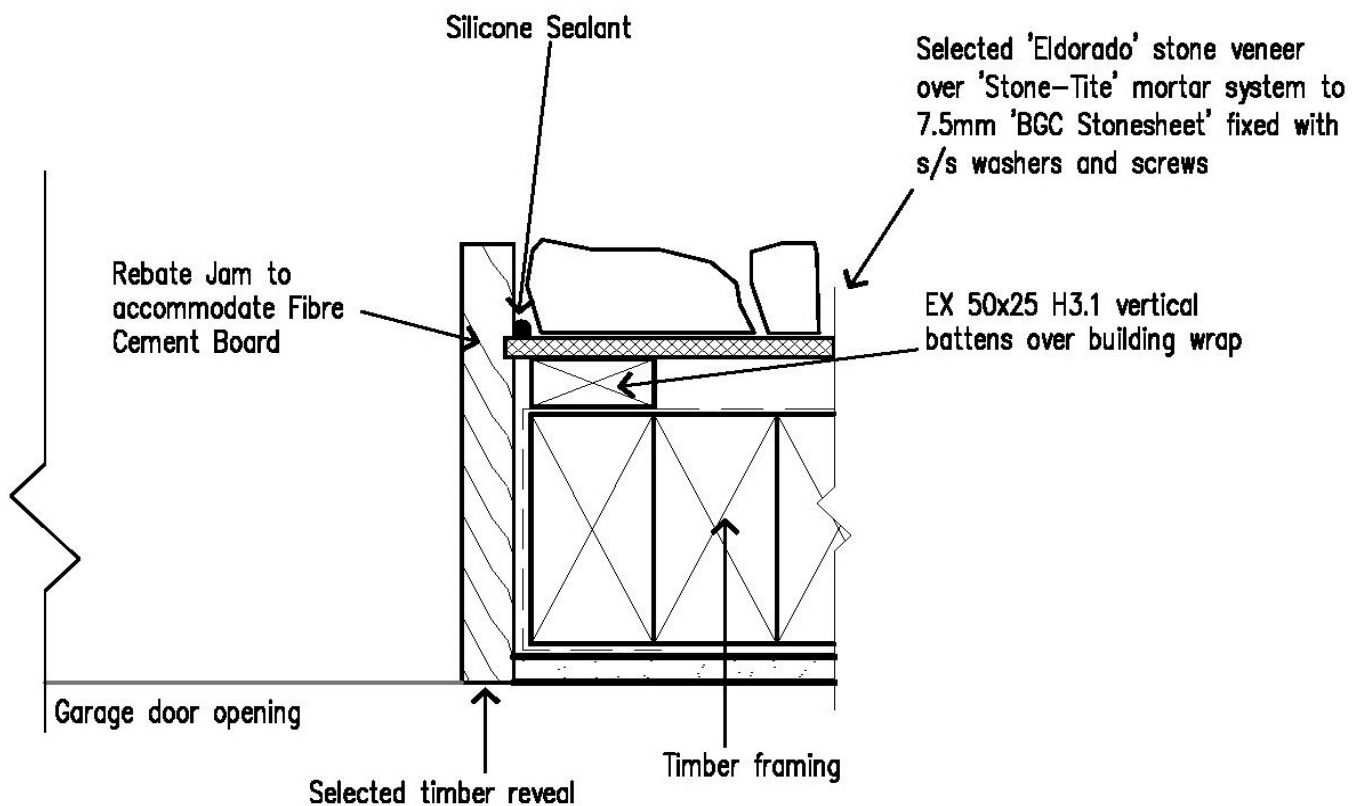

**HARD AS ROCKS SUGGESTED DETAILS ONLY – DETAILS TO BE APPROVED BY LOCAL AUTHORITY & COMPLY WITH NZBC Builders** are responsible for the supply and installation of the fibre cement board with Hard as Rocks Tags, all relevant watertight flashings behind all fibre cement board sheet joints, sealant over the top of the sheet joints and sealing around joinery and all workmanship and installation of the substrate to meet Hard as Rocks Technical Literature and NZBC.

## (5a) Window Head

Selected 'Eldorado' stone veneer over 'Stone-Tite' mortar system to 7.5mm 'BGC Stonesheet' fixed with s/s screws and Hard as Rocks Tags®

'Protecto' flashing tape lapped over galv. head flashing and building wrap

EX50x25 H3.1 vertical battens over building wrap. Non-continuous horizontal battens to noggs

Galv. or colour steel head flashing with 10mm drip edge & 35mm min upstand. Ends of flashing to be turned up or siliconed to prevent water ingress

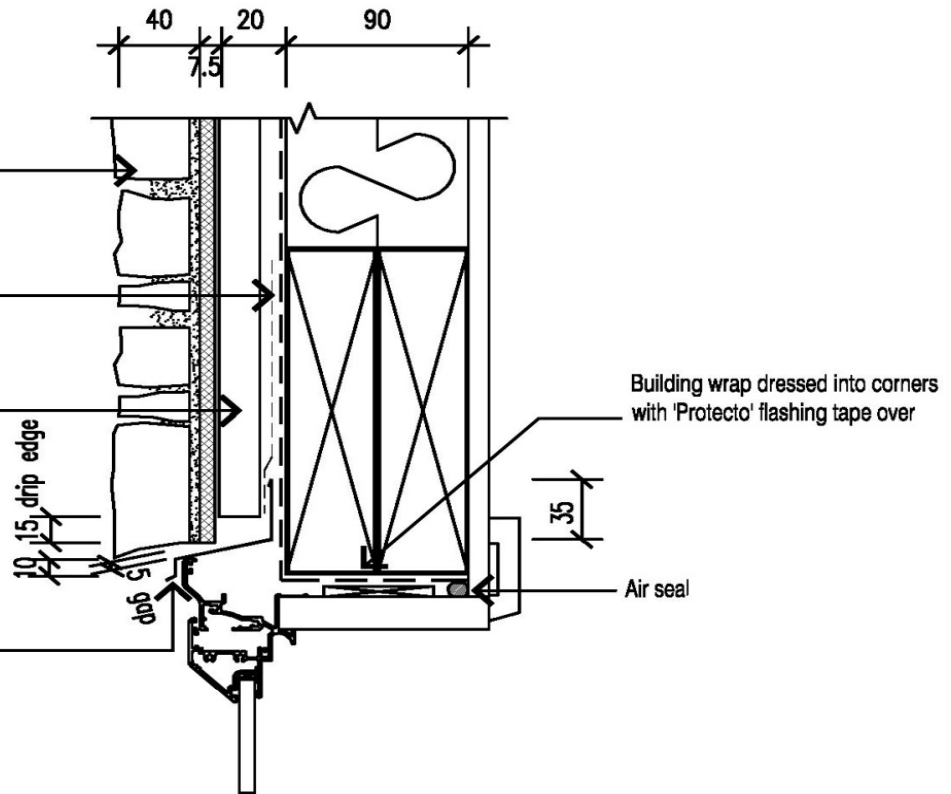

## (5d) Window Sill

Building wrap dressed into opening

Sikaflex MS sealant between joinery and substrate

Non-continuous batten

'Protecto' sill flashing continuous along sill, min. 100mm up jambs and 50mm onto face of building wrap  
Selected 'Eldorado' stone veneer over 'Stone-Tite' mortar system to 7.5mm 'BGC Stonesheet' fixed with s/s screws and Hard as Rocks Tags®

EX50x25 H3.1 vertical battens over building wrap. Non-continuous horizontal battens to noggs and bottom plate

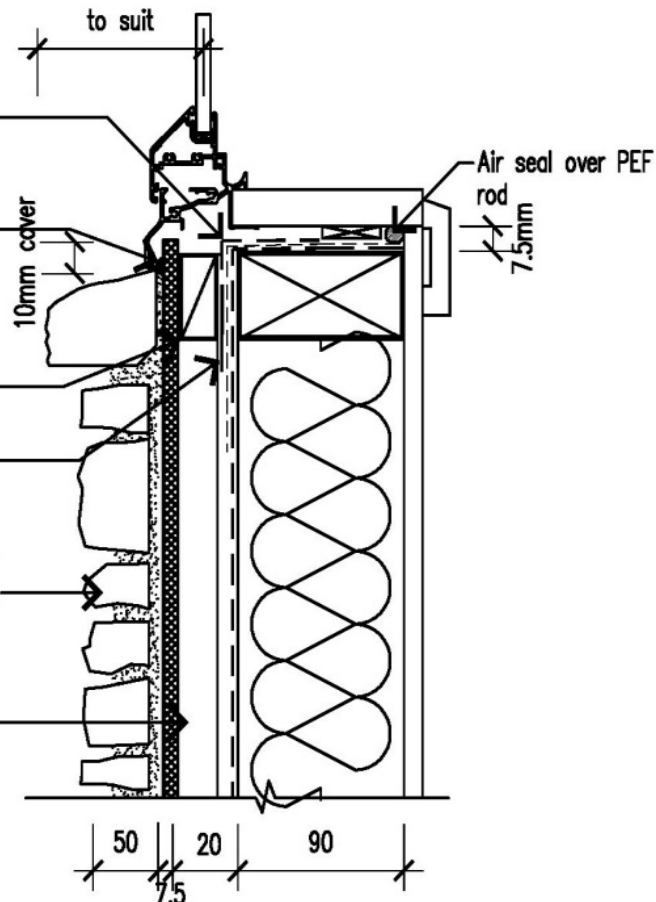

**HARD AS ROCKS SUGGESTED DETAILS ONLY – DETAILS TO BE APPROVED BY LOCAL AUTHORITY & COMPLY WITH NZBC**

**Builders** are responsible for the supply and installation of the fibre cement board with Hard as Rocks Tags, all relevant watertight flashings behind all fibre cement board sheet joints, sealant over the top of the sheet joints and sealing around joinery and all workmanship and installation of the substrate to meet Hard as Rocks Technical Literature and NZBC.

### (5c) Window Jamb

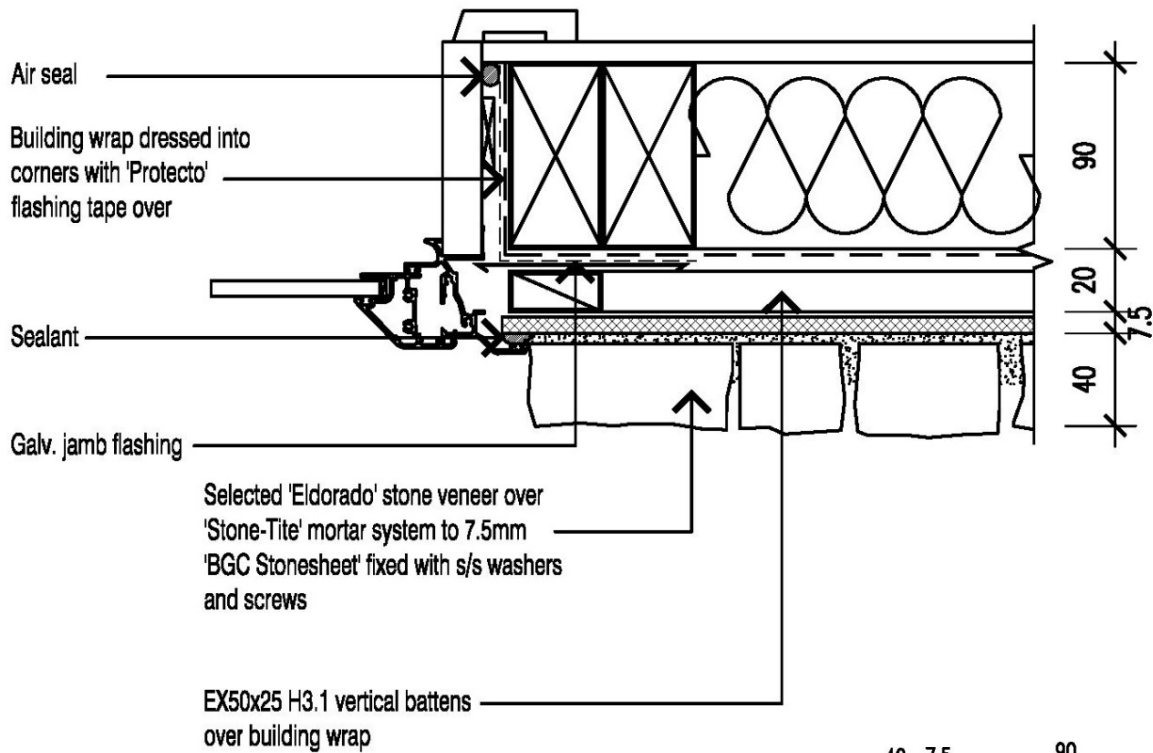

### (5h) Internal Corner with Aluminium Joinery

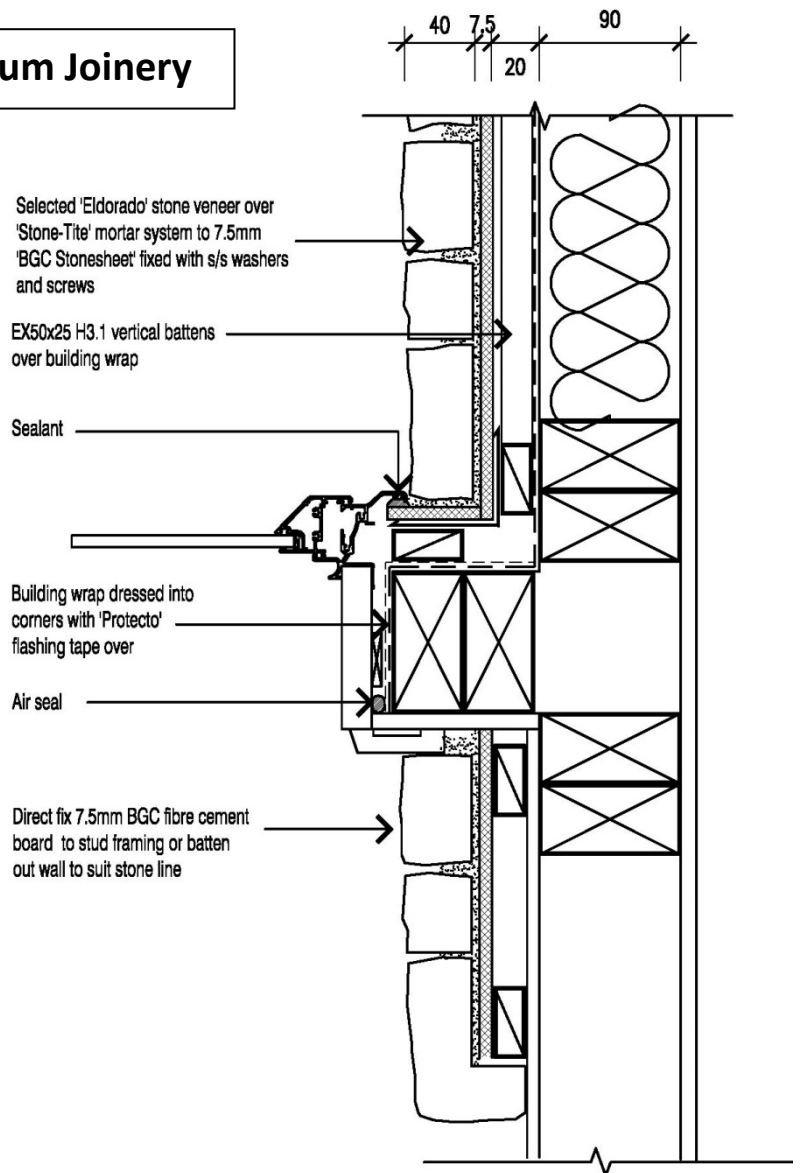

**HARD AS ROCKS SUGGESTED  
DETAILS ONLY – DETAILS TO BE  
APPROVED BY LOCAL AUTHORITY  
& COMPLY WITH NZBC**

**Builders** are responsible for the supply and installation of the fibre cement board with Hard as Rocks Tags, all relevant watertight flashings behind all fibre cement board sheet joints, sealant over the top of the sheet joints and sealing around joinery and all workmanship and installation of the substrate to meet Hard as Rocks Technical Literature and NZBC.

## (2d) Internal Corner with W/B's

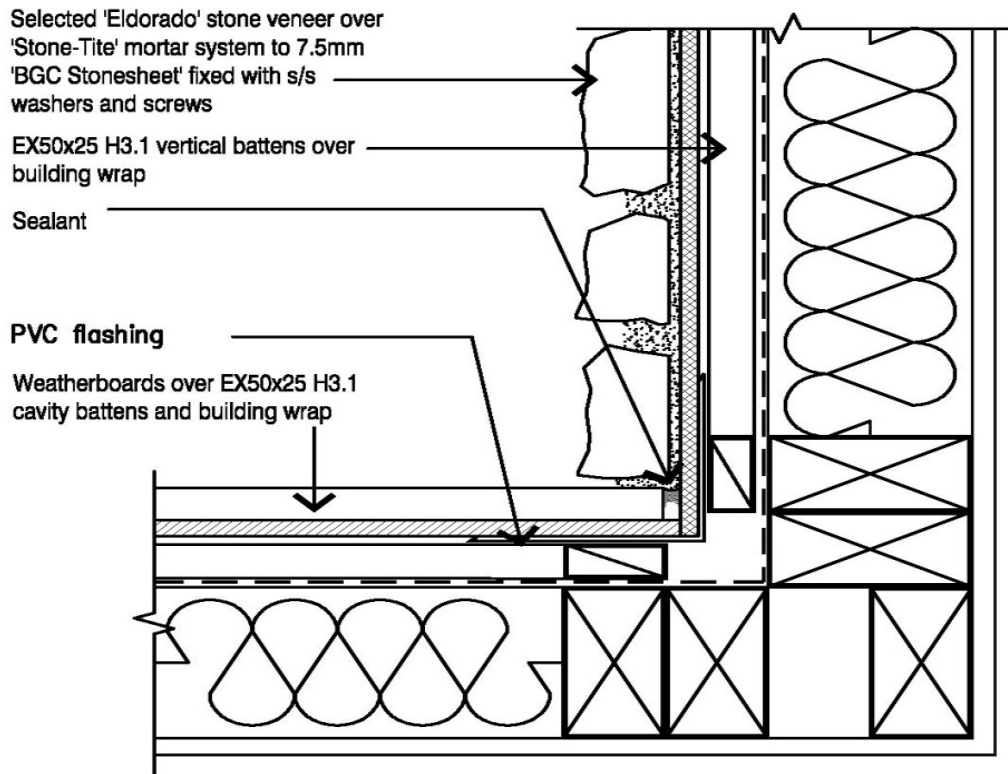

## (2g) External Corner with W/B's

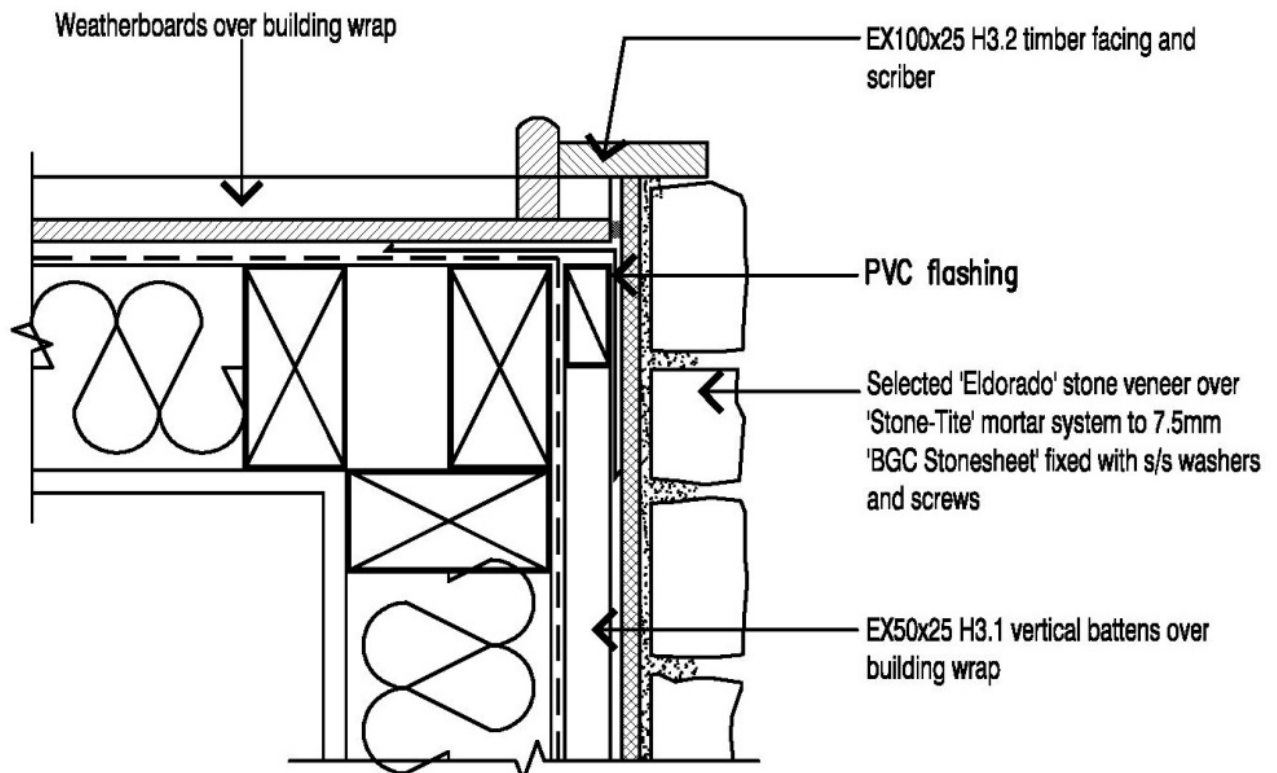

**HARD AS ROCKS SUGGESTED DETAILS ONLY – DETAILS TO BE APPROVED BY LOCAL AUTHORITY & COMPLY WITH NZBC**

**Builders** are responsible for the supply and installation of the fibre cement board with Hard as Rocks Tags, all relevant watertight flashings behind all fibre cement board sheet joints, sealant over the top of the sheet joints and sealing around joinery and all workmanship and installation of the substrate to meet Hard as Rocks Technical Literature and NZBC.



### (3f) Horizontal transition with W/B's

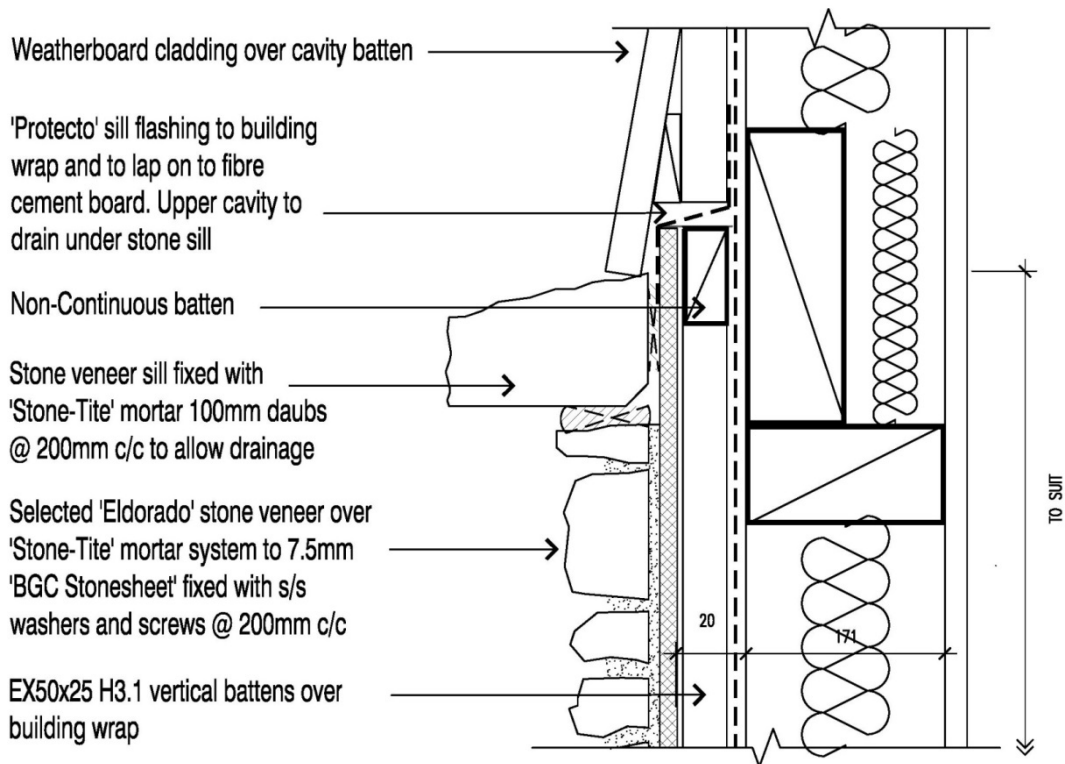

### (3b) Vertical transition with W/B's

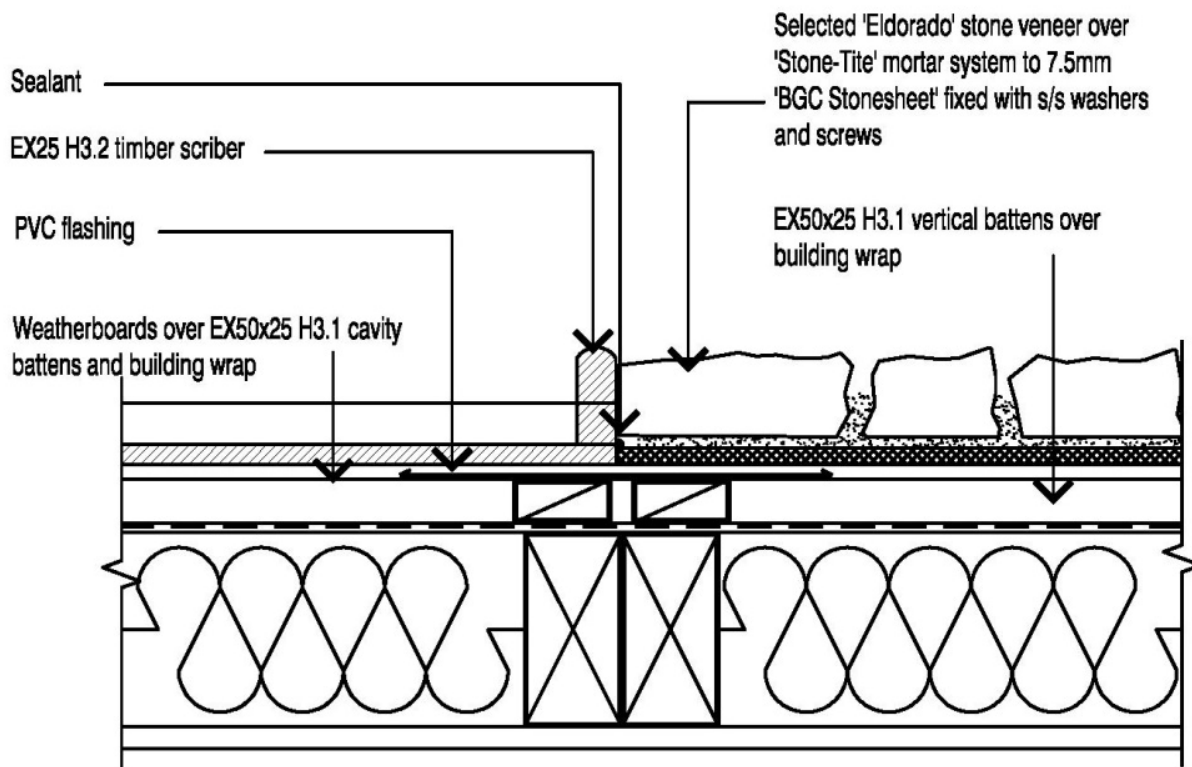

**HARD AS ROCKS SUGGESTED DETAILS ONLY – DETAILS TO BE APPROVED BY LOCAL AUTHORITY & COMPLY WITH NZBC**  
**Builders** are responsible for the supply and installation of the fibre cement board with Hard as Rocks Tags, all relevant watertight flashings behind all fibre cement board sheet joints, sealant over the top of the sheet joints and sealing around joinery and all workmanship and installation of the substrate to meet Hard as Rocks Technical Literature and NZBC.

## (2f) Internal Corner with Ply

Selected 'Eldorado' stone veneer over 'Stone-Tite' mortar system to 7.5mm 'BGC Stonesheet' fixed with s/s washers and screws

EX50x25 H3.1 vertical battens over building wrap

Sealant between boards

PVC flashing

H3 plywood cladding over EX50x25 H3.1 cavity battens and building wrap

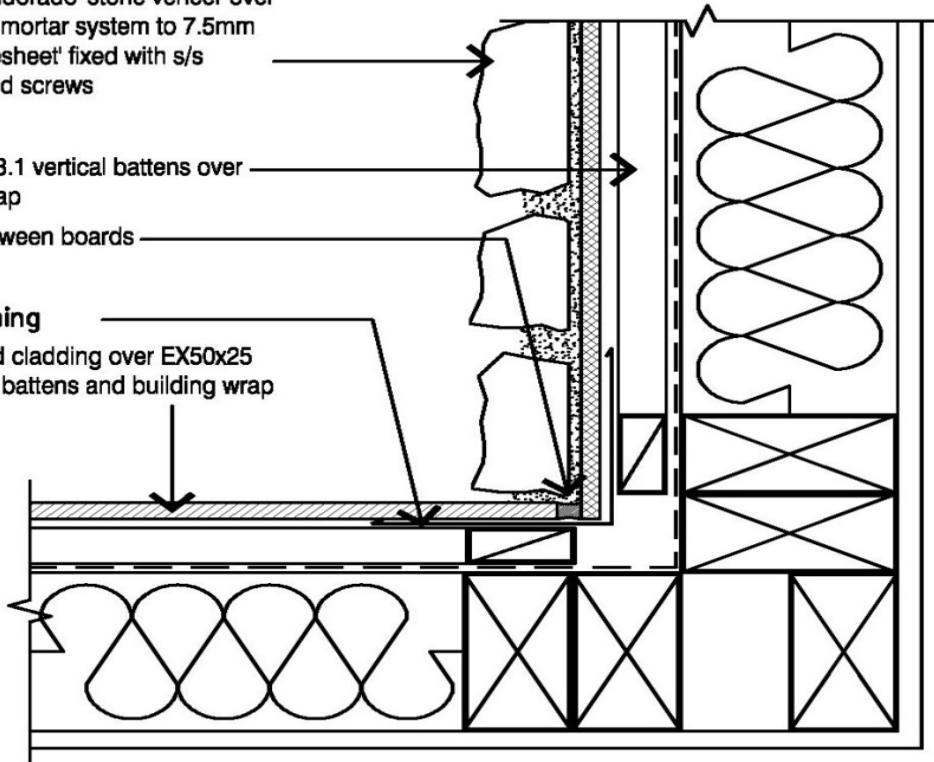

## (2i) External Corner with Ply - Facing

H3 plywood cladding over EX50x25 H3.1 cavity battens and building wrap

EX75x25 H3.2 timber facing

Sealant between boards

PVC flashing

Selected 'Eldorado' stone veneer over sand/cement mortar with Febond SBR additive to 7.5mm BGC Durasheet backing sheet

EX50x25 H3.1 vertical battens over building wrap

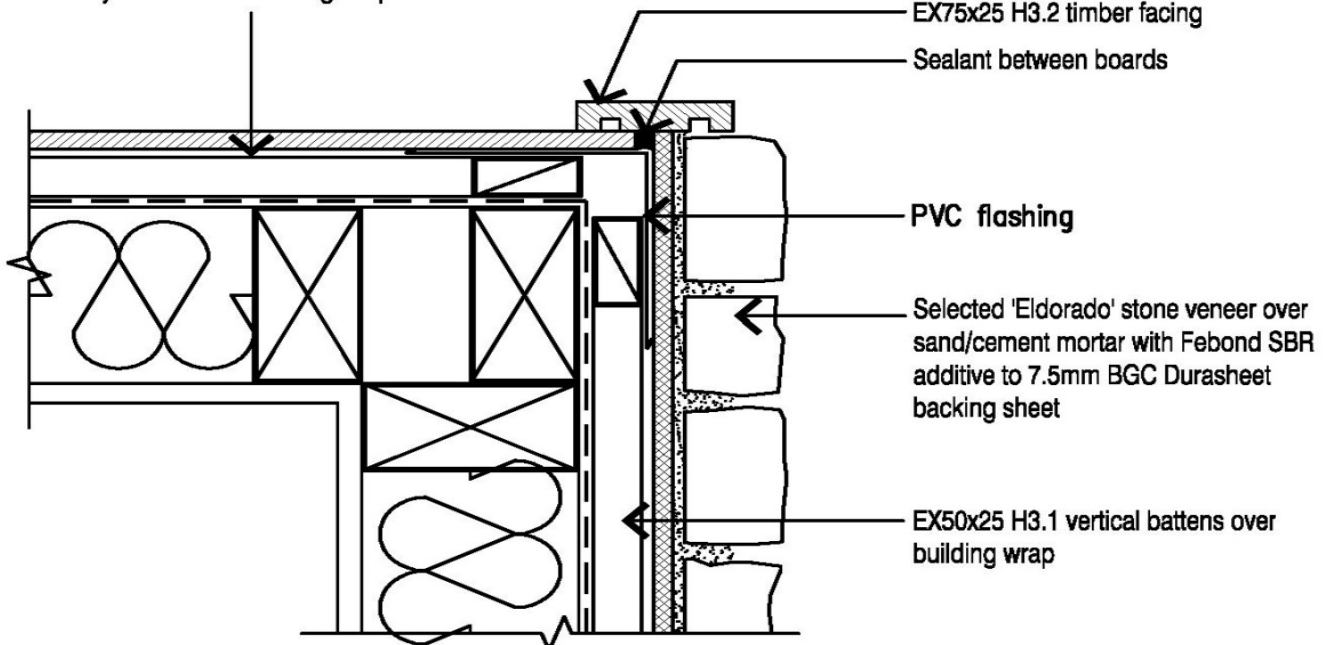

**HARD AS ROCKS SUGGESTED DETAILS ONLY – DETAILS TO BE APPROVED BY LOCAL AUTHORITY & COMPLY WITH NZBC**  
**Builders** are responsible for the supply and installation of the fibre cement board with Hard as Rocks Tags, all relevant watertight flashings behind all fibre cement board sheet joints, sealant over the top of the sheet joints and sealing around joinery and all workmanship and installation of the substrate to meet Hard as Rocks Technical Literature and NZBC.

### (3p) Horizontal Transition with Ply

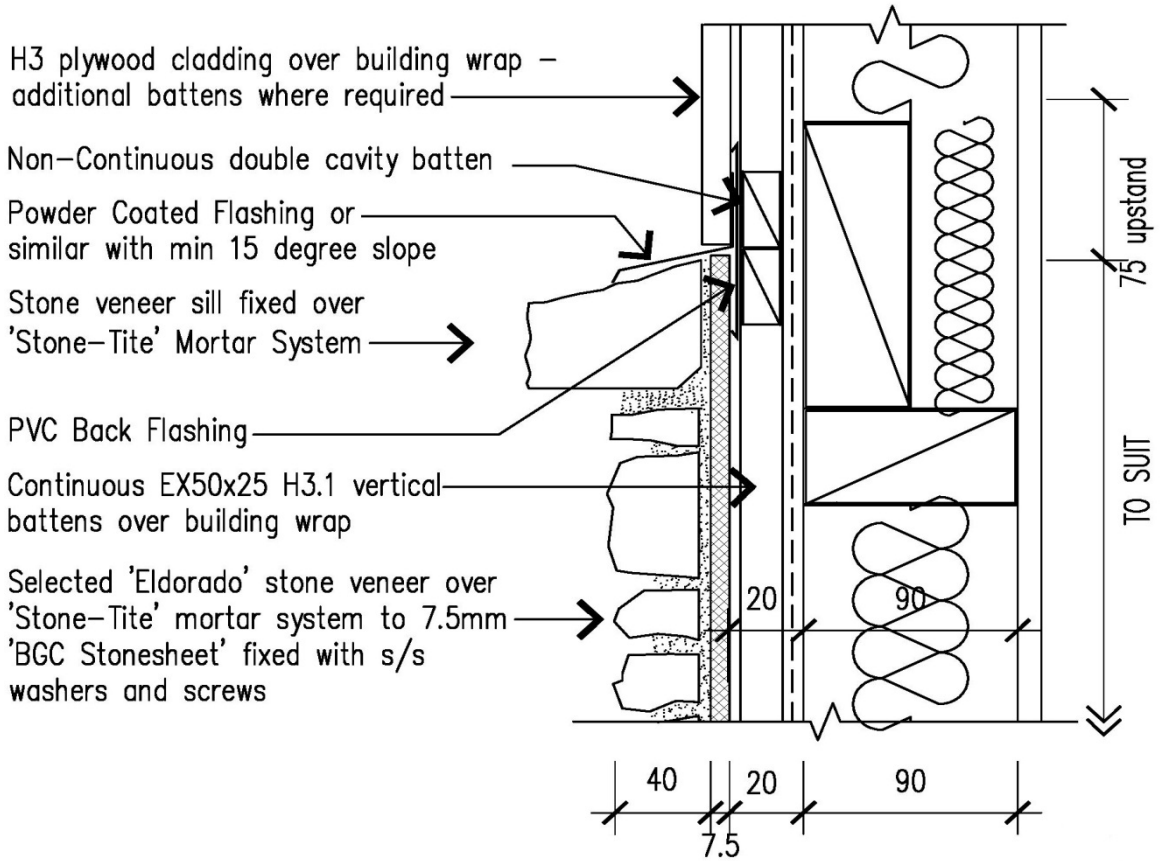

### (3d) Vertical Transition with Ply

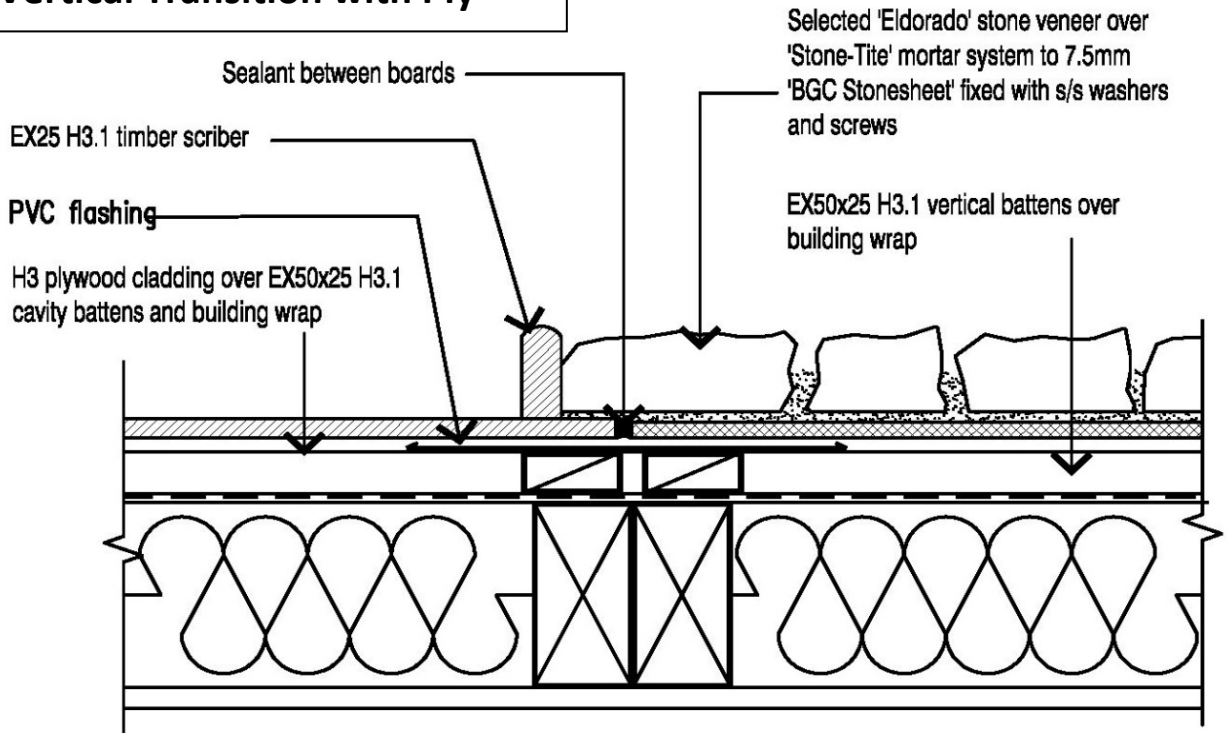

**HARD AS ROCKS SUGGESTED DETAILS ONLY – DETAILS TO BE APPROVED BY LOCAL AUTHORITY & COMPLY WITH NZBC**  
**Builders** are responsible for the supply and installation of the fibre cement board with Hard as Rocks Tags, all relevant watertight flashings behind all fibre cement board sheet joints, sealant over the top of the sheet joints and sealing around joinery and all workmanship and installation of the substrate to meet Hard as Rocks Technical Literature and NZBC.

## (2l) Internal Corner with EIFS or AAC Panel

Selected 'Eldorado' stone veneer over  
'Stone-Tite' mortar system to 7.5mm  
'BGC Stonesheet' fixed with s/s washers  
and screws

EX50x25 H3.1 vertical battens over  
building wrap

EIFS and mesh to return onto fibre cement  
board 100mm min

Sealant between boards

PVC flashing

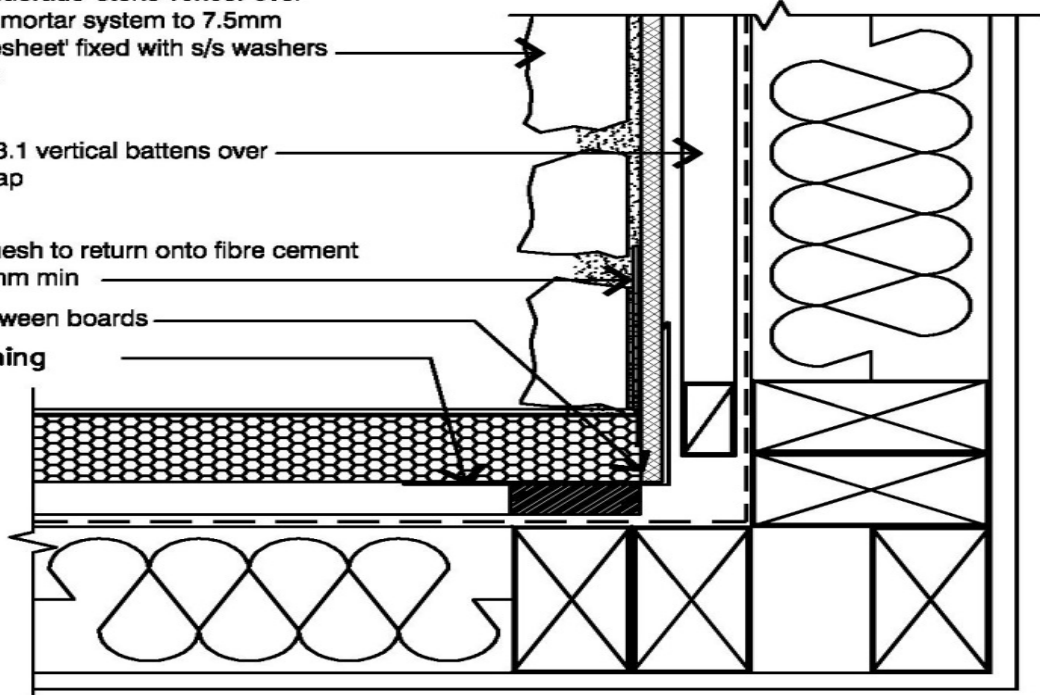

## (2k) External Corner with EIFS or AAC Panel

Cavity based EIFS over building wrap  
and timber framing

Sealant between boards

PVC cap to reinforce edge (2 piece  
or custom made)

EIFS and mesh to return onto fibre cement  
board 100mm min.

PVC flashing

Selected 'Eldorado' stone veneer over  
'Stone-Tite' mortar system to 7.5mm  
'BGC Stonesheet' fixed with s/s washers  
and screws

EX50x25 H3.1 vertical battens over  
building wrap

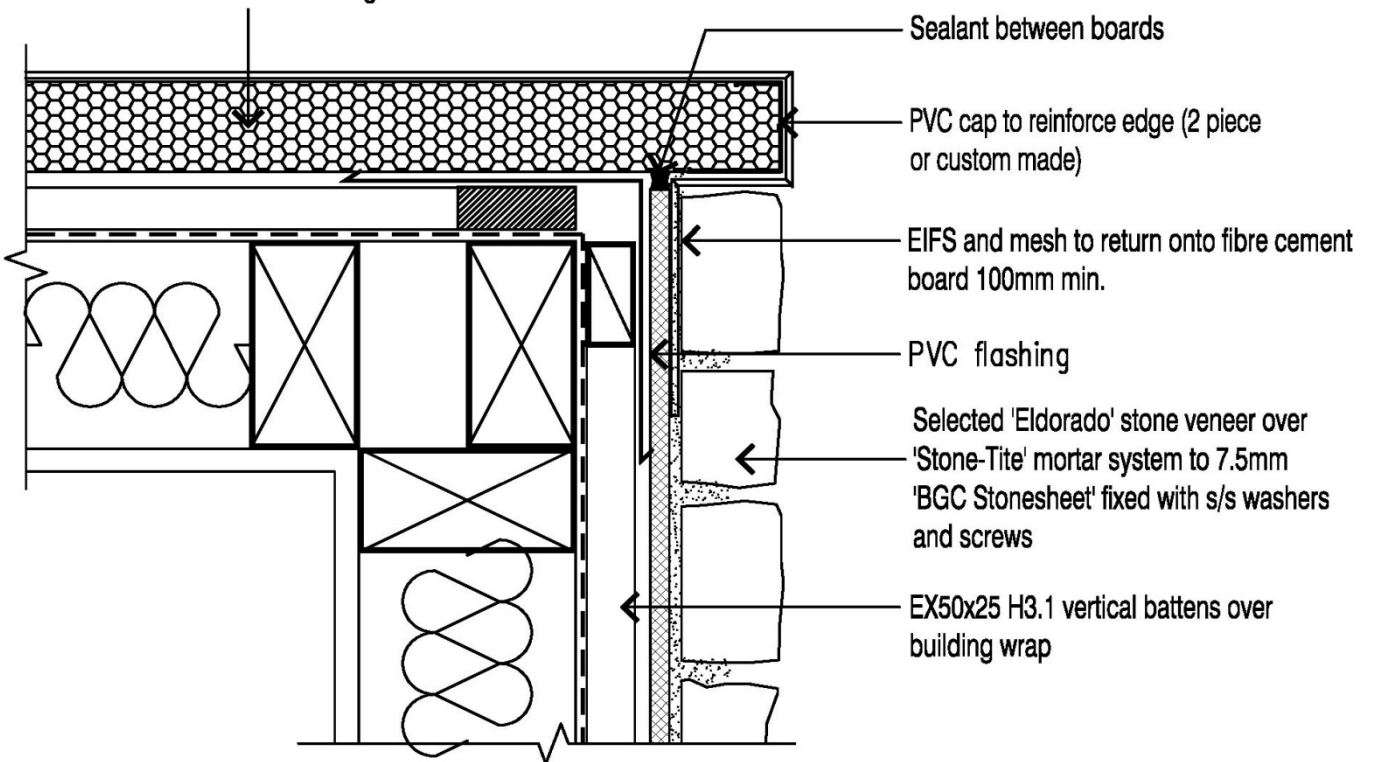

**HARD AS ROCKS SUGGESTED DETAILS ONLY – DETAILS TO BE APPROVED BY LOCAL AUTHORITY & COMPLY WITH NZBC**  
Builders are responsible for the supply and installation of the fibre cement board with Hard as Rocks Tags, all relevant watertight flashings behind all fibre cement board sheet joints, sealant over the top of the sheet joints and sealing around joinery and all workmanship and installation of the substrate to meet Hard as Rocks Technical Literature and NZBC.

### (3i) Horizontal transition with EIFS or AAC Panel

Cavity based EIFS system  
over building wrap and timber framing

Non continuous horizontal battens fixed to  
studs and noggs

MS sealant

Stone veneer sill stone

100mm PVC Back Flashing

Selected 'Eldorado' stone veneer over  
'Stone-Tite' mortar system to 7.5mm  
'BGC Stonesheet' fixed with s/s  
washers and screws

EX50x25 H3.1 vertical battens over  
building wrap

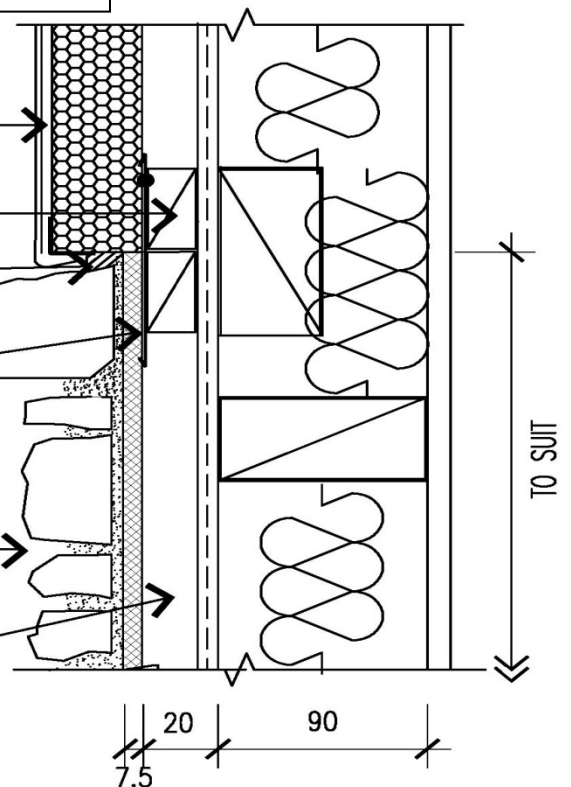

### (3e) Vertical Transition with EIFS or AAC Panel

EIFS and mesh to return on to  
fibre cement board 100mm min

Cavity based EIFS over building wrap  
and timber framing

PVC flashing

Selected 'Eldorado' stone veneer over  
'Stone-Tite' mortar system to 7.5mm  
'BGC Stonesheet' fixed with s/s washers  
and screws

EX50x50 H3.1 vertical battens over  
building wrap

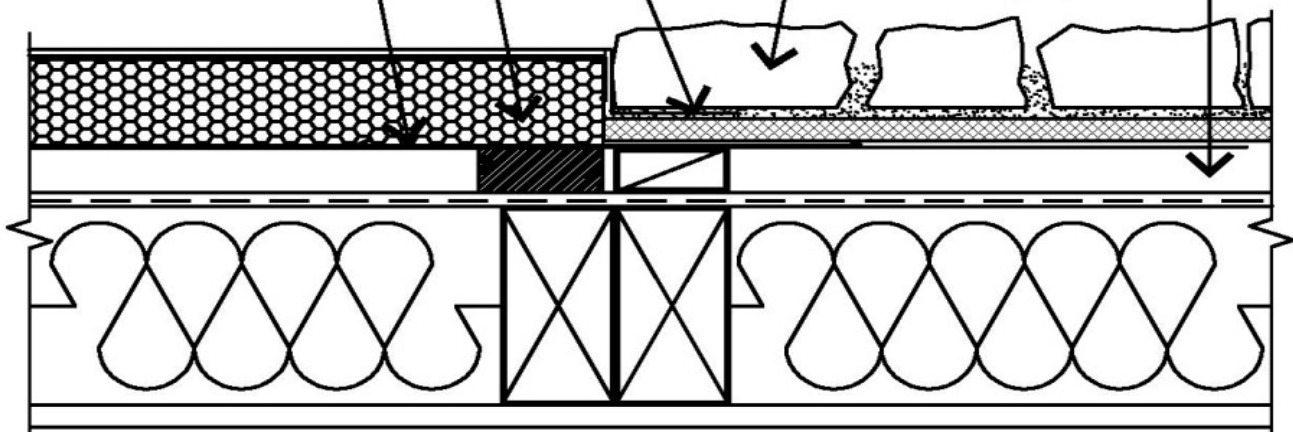

**HARD AS ROCKS SUGGESTED DETAILS ONLY – DETAILS TO BE APPROVED BY LOCAL AUTHORITY & COMPLY WITH NZBC**  
Builders are responsible for the supply and installation of the fibre cement board with Hard as Rocks Tags, all relevant watertight flashings behind all fibre cement board sheet joints, sealant over the top of the sheet joints and sealing around joinery and all workmanship and installation of the substrate to meet Hard as Rocks Technical Literature and NZBC.

### (4a) Chimney Cap Detail

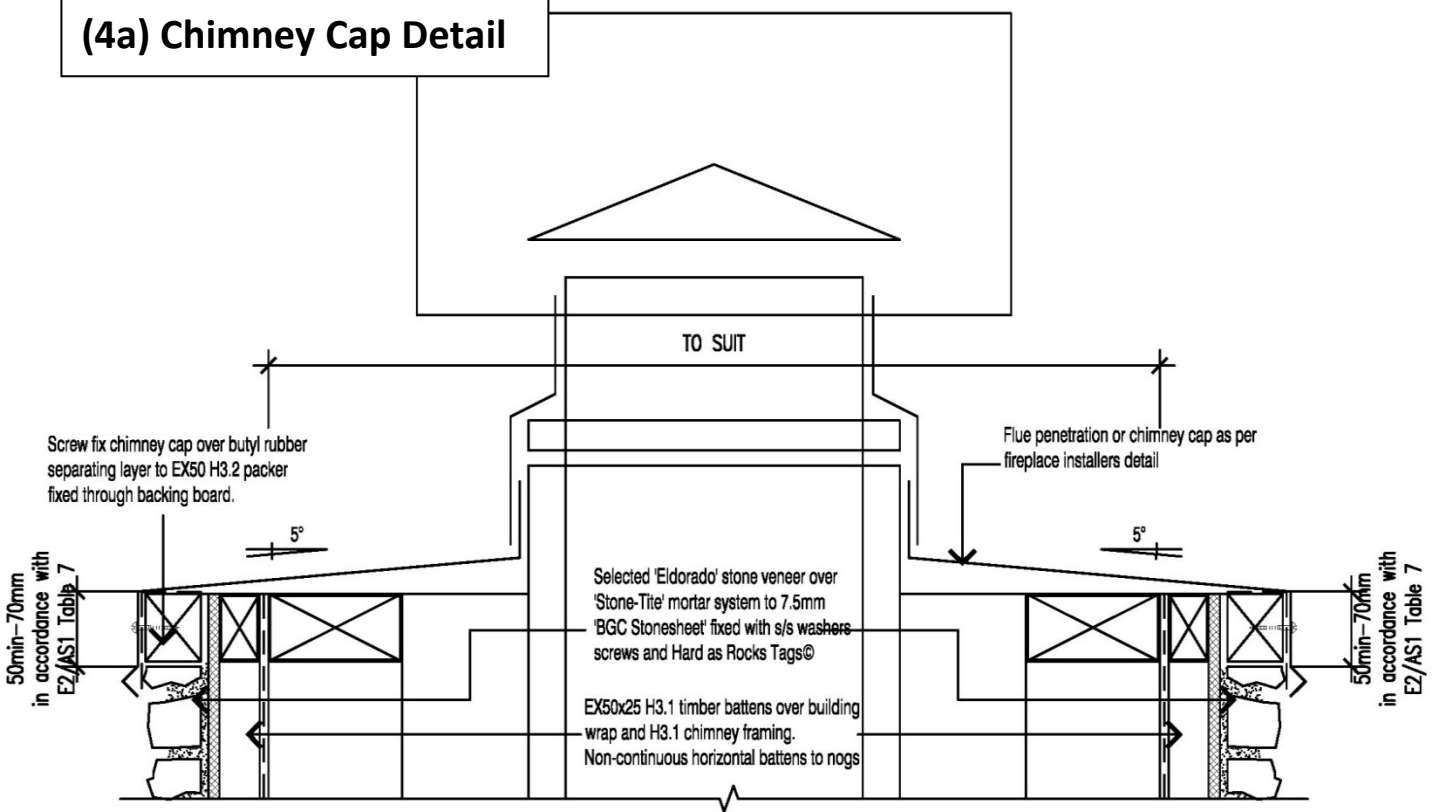

### (4c) Roof Abutment - Longrun

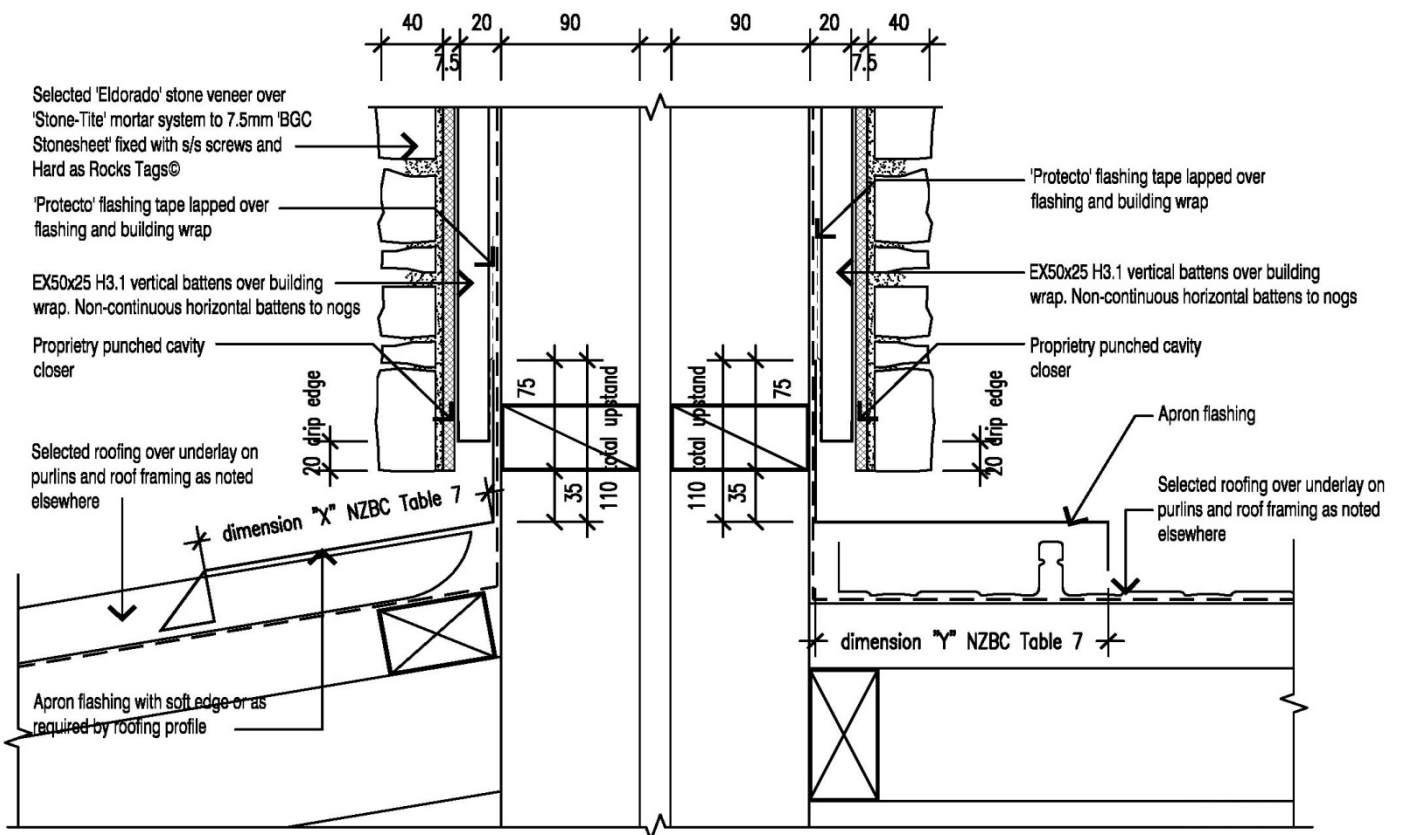

**HARD AS ROCKS SUGGESTED DETAILS ONLY – DETAILS TO BE APPROVED BY LOCAL AUTHORITY & COMPLY WITH NZBC**

**Builders** are responsible for the supply and installation of the fibre cement board with Hard as Rocks Tags, all relevant watertight flashings behind all fibre cement board sheet joints, sealant over the top of the sheet joints and sealing around joinery and all workmanship and installation of the substrate to meet Hard as Rocks Technical Literature and NZBC.

## (4f) Roof Abutment Metal Tile

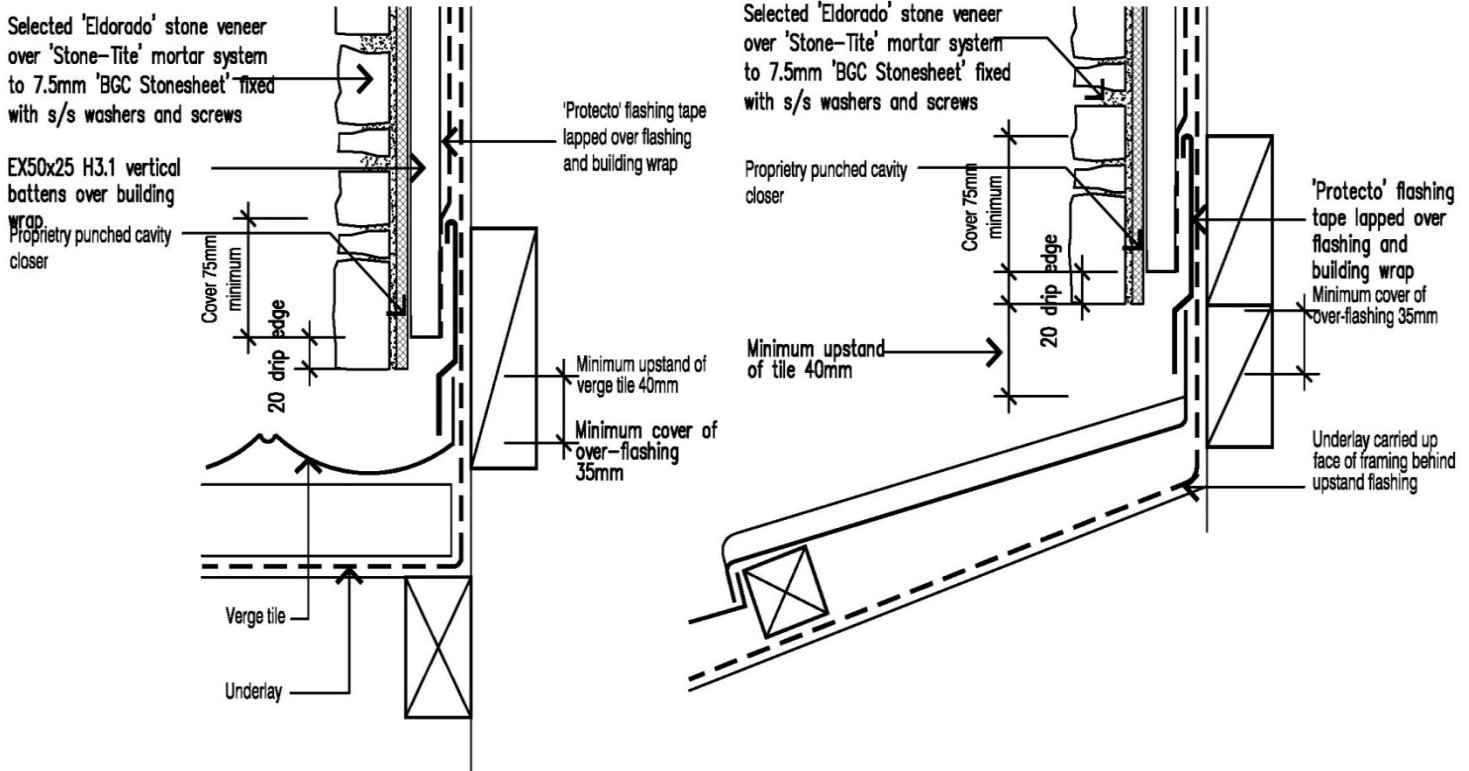

## (4h) Parapet detail

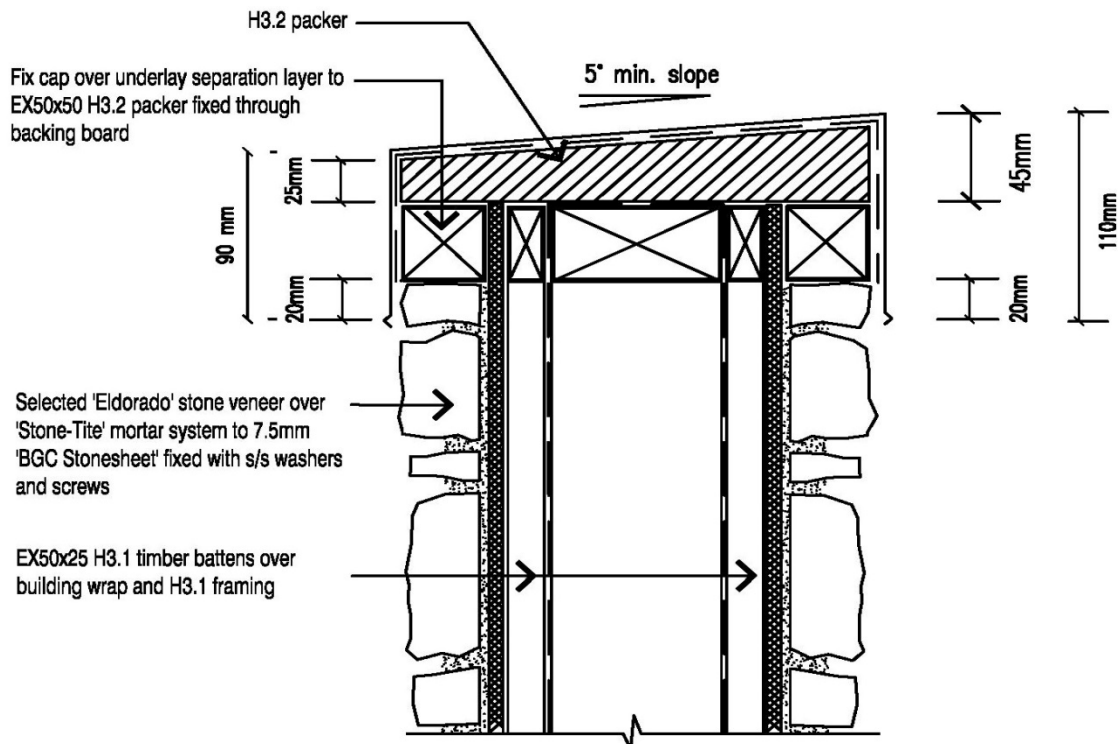

**HARD AS ROCKS SUGGESTED DETAILS ONLY – DETAILS TO BE APPROVED BY LOCAL AUTHORITY & COMPLY WITH NZBC**  
**Builders** are responsible for the supply and installation of the fibre cement board with Hard as Rocks Tags, all relevant watertight flashings behind all fibre cement board sheet joints, sealant over the top of the sheet joints and sealing around joinery and all workmanship and installation of the substrate to meet Hard as Rocks Technical Literature and NZBC.

For product selection and colour choices please refer to the website or call 0800 353 672 to contact your local Hard as Rocks Ltd distributor and arrange to see samples or displays.

Do you have a technical question?? Please contact us  
Hard as Rocks Ltd, PO Box 1706, Taupo  
P: 07 3789926 F: 0800 353 672



W: [www.hardasrocks.co.nz](http://www.hardasrocks.co.nz) E: [info@hardasrocks.co.nz](mailto:info@hardasrocks.co.nz)

Manawatu - [manawatu@hardasrocks.co.nz](mailto:manawatu@hardasrocks.co.nz)  
Wellington/Wairarapa - [wellington@hardasrocks.co.nz](mailto:wellington@hardasrocks.co.nz)  
Nelson - [marlborough@hardasrocks.co.nz](mailto:marlborough@hardasrocks.co.nz)  
West Coast - [westcoast@hardasrocks.co.nz](mailto:westcoast@hardasrocks.co.nz)  
Canterbury - [canterbury@hardasrocks.co.nz](mailto:canterbury@hardasrocks.co.nz)  
Otago/Queenstown-Lakes - [otago@hardasrocks.co.nz](mailto:otago@hardasrocks.co.nz)  
Southland - [southland@hardasrocks.co.nz](mailto:southland@hardasrocks.co.nz)

Northland - [northland@hardasrocks.co.nz](mailto:northland@hardasrocks.co.nz)  
Auckland - [auckland@hardasrocks.co.nz](mailto:auckland@hardasrocks.co.nz)  
Waikato/Coromandel - [waikato@hardasrocks.co.nz](mailto:waikato@hardasrocks.co.nz)  
Hawkes Bay - [hawkesbay@hardasrocks.co.nz](mailto:hawkesbay@hardasrocks.co.nz)  
Gisborne - [gisborne@hardasrocks.co.nz](mailto:gisborne@hardasrocks.co.nz)  
Bay of Plenty - [bayofplenty@hardasrocks.co.nz](mailto:bayofplenty@hardasrocks.co.nz)  
Taupo/Rotorua/Ohakune - [taupo@hardasrocks.co.nz](mailto:taupo@hardasrocks.co.nz)

For updates and a full set of suggested detail drawings please refer to the Technical Information section on the website.



© 2024 HARD AS ROCKS

ALL INFORMATION AND IMAGES CONTAINED IN THIS CONSTRUCTION GUIDE ARE THE COPYRIGHT OF HARD AS ROCKS